

Notebook

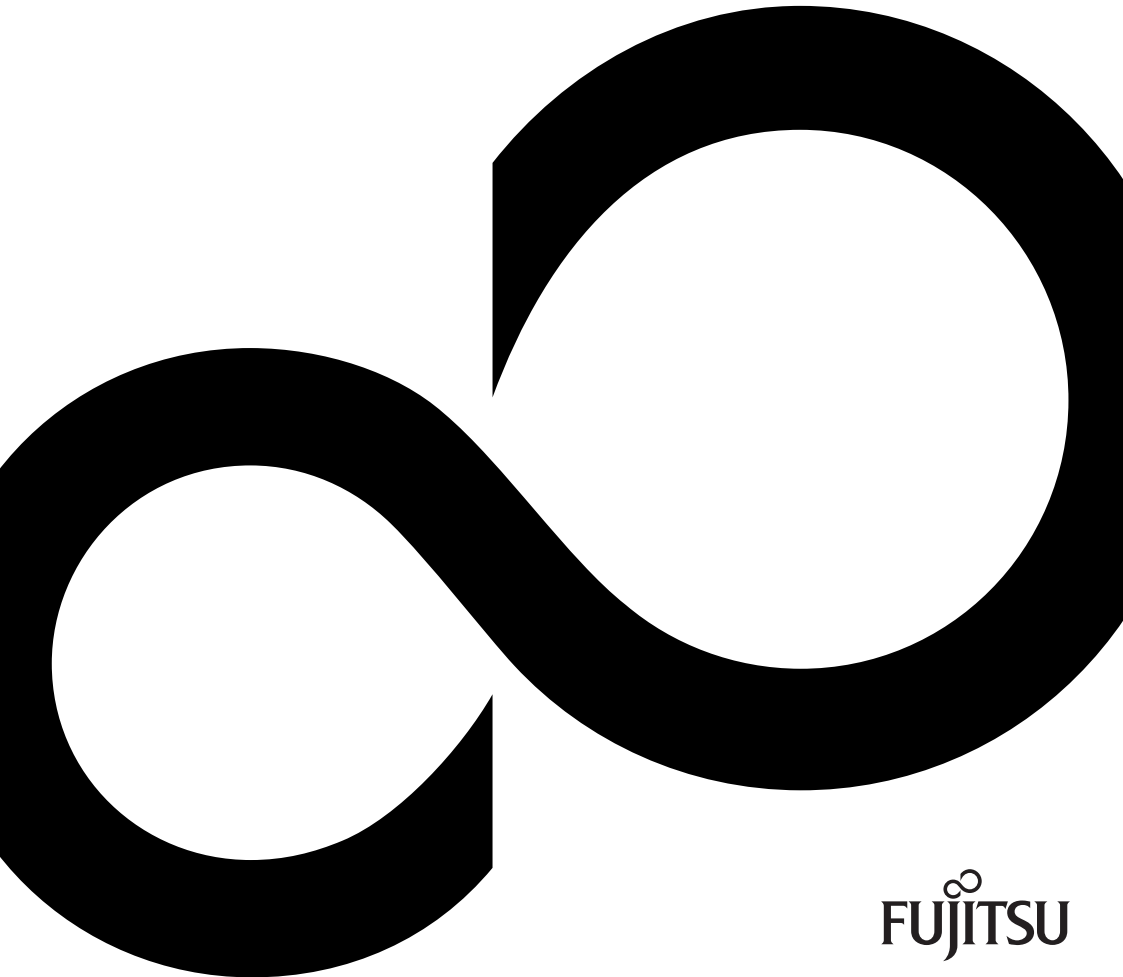

Are there ...

... any technical problems or other questions that you would like help with?

Please contact:

- our Hotline/Help Desk (refer to the enclosed Help Desk List or go to: ["http://ts.fujitsu.com/helpdesk"](http://ts.fujitsu.com/helpdesk))
- your sales partner
- your sales office

Additional information is contained in the Help Desk list and the "Warranty" manual. The "Warranty" manual can be found on the supplied "Drivers & Utilities" CD/DVD.

The latest information about our products, useful tips, updates etc. is available from our website: ["http://ts.fujitsu.com"](http://ts.fujitsu.com)

**Copyright**

© Fujitsu Technology Solutions 2009
2009/08

Published by

Fujitsu Technology Solutions GmbH
Mies-van-der-Rohe-Straße 8
80807 München, Germany

Contact

<http://ts.fujitsu.com/support>

All rights reserved, including intellectual property rights. Technical data subject to modifications and delivery subject to availability. Any liability that the data and illustrations are complete, actual or correct is excluded. Designations may be trademarks and/or copyrights of the respective manufacturer, the use of which by third parties for their own purposes may infringe the rights of such owner. For further information see http://ts.fujitsu.com/terms_of_use.html

Order-No. Fujitsu Technology Solutions: A26391-K200-Z226-1-7619

Professional Notebook

Operating Manual

Innovative technology...	1
Important notes	3
Preparing the notebook for use	6
Using your notebook	9
Security functions	32
Connecting external devices	46
Energy saving functions	50
Settings in BIOS Setup	52
Troubleshooting and tips	54
Manufacturer's notes	66
Index	72

Adobe and Acrobat are trademarks of Adobe Systems Incorporated and may be protected in certain countries.

The Bluetooth trademarks are the property of Bluetooth SIG, Inc., U.S.A. licensed for Fujitsu Technology Solutions GmbH.

Intel is a registered trademark, Core is a trademark of Intel Corporation, USA.

Kensington and MicroSaver are registered trademarks of ACCO World Corporation.

Microsoft, MS Windows and Windows Vista are registered trademarks of the Microsoft Corporation.

All other trademarks referenced are trademarks or registered trademarks of their respective owners, whose protected rights are acknowledged.

Copyright © Fujitsu Technology Solutions GmbH 2009

All rights reserved, including rights of translation, reproduction by printing, copying or similar methods, in part or in whole.

In the event of violations, perpetrators will be liable to prosecution for damages.

All rights reserved, including rights created by patent grant or registration of a utility model or design.

Subject to availability and technical modifications.

Contents

Innovative technology...	1
Notational conventions	2
Important notes	3
safety information	3
Additional safety notes for devices with radio components	3
Travelling with your notebook	4
Before you travel	4
Transporting your notebook	4
Cleaning the notebook	5
Preparing the notebook for use	6
Unpacking and checking the delivery	6
Selecting the location	6
Mains adapter connecting	7
Switching the notebook on for the first time	8
Using your notebook	9
Keyboard	9
Virtual numeric keypad	11
TouchStick, Touchpad, TouchStick and Touchpad buttons	12
Using Touchpad buttons	13
LCD screen	14
Information on LCD screen	14
Screen settings	15
Adjusting the resolution (under Windows XP)	15
Adjusting the resolution (under Windows Vista)	15
Selecting the font size (under Windows XP)	15
Selecting the font size (under Windows Vista)	16
Adjusting the brightness of the display	16
Synchronising the display on the LCD screen and an external monitor	16
Adjusting the speed of the mouse pointer (under Windows XP)	16
Battery	17
Charging, caring for and maintaining the battery	17
Modules (device-dependent)	19
Removing a module	20
Installing a module	21
Optical drive	22
Handling CD/DVDs	22
CD/DVD indicator	22
Inserting or removing a CD/DVD	23
Manual removal (emergency removal)	23
Memory cards	24
Memory card inserting	24
Removing a memory Card	24
PC cards and ExpressCards	25
Inserting a card	26
Removing the card	28
Integrated 56k modem (optional)	30
Connecting notebook modem to telephone wall socket	30
Connecting the notebook to a LAN	31

Security functions	32
Brief overview of security functions	33
Using Kensington Lock	34
Setting up the fingerprint sensor (device-dependent)	34
Configuring password protection in BIOS Setup	35
Password protection for BIOS Setup (supervisor and user password)	35
Password protection for starting the operating system	37
Password protection for the hard disk	38
Boot from Removable Media	40
Owner Information (device-dependent)	41
Virus Warning (device-dependent)	41
SmartCard reader (device-dependent)	42
Inserting the SmartCard	42
SmartCard as software protection (SmartCase™ Logon+)	43
Trusted Platform Module (TPM) (device-dependent)	44
Enabling TPM	45
Disabling TPM	45
Connecting external devices	46
Connecting devices to the notebook	46
Disconnecting devices from the notebook	46
Connecting an external monitor	47
Connecting an external monitor to the notebook	47
Setting the refresh rate for your external monitor	47
Connecting USB devices (printer, mouse, keyboard, etc.)	48
Device drivers	48
Connecting external audio devices	48
High Definition Audio	48
Microphone port	48
Audio output (Line out)/SPDIF (optional)	48
Connecting an external device to S-Video Out (device-dependent)	49
Activating the external TV / projector	49
Connecting FireWire devices (device-dependent)	49
Energy saving functions	50
Standby mode	51
Settings in BIOS Setup	52
BIOS Setup starting	52
Using the BIOS Setup	52
Exiting the BIOS Setup	52
Exit Saving Changes	53
Exit Discarding Changes	53
Load Setup Default	53
Discard Changes	53
Save Changes	53
Troubleshooting and tips	54
Help if problems occur	54
Troubleshooting	54
The notebook's date or time is incorrect	54
No display appears on the screen, the power-on indicator flashes	55
The notebook's LCD screen remains blank	55
The LCD screen is difficult to read	56

The external monitor remains blank	56
The external monitor is blank or the image is unstable	57
Battery indicator no longer appears in status indicator panel	58
The battery discharges too quickly	58
The notebook cannot be started	59
The notebook does not react	59
The notebook shuts down suddenly	59
The ON/OFF button does not respond properly	60
The wireless connection to a network does not work	60
The mouse does not work	60
The printer does not print	61
No sound or audio signal to the internal or external loudspeakers	62
The CD/DVD does not work – no sound during CD/DVD playback	63
User and/or supervisor password forgotten	63
Acoustic warnings	63
Error messages on the screen	64
Restoring the hard disk contents under Windows	65
Manufacturer's notes	66
Disposal and recycling	66
Copyright-protected technology	66
CE marking	66
Regulatory notices	67
Regulatory information for notebooks without radio device	67
DOC (Industry CANADA) notices	68
FCC Regulatory information for notebooks with radio device	70
Index	72

Innovative technology...

... and an ergonomic design make your notebook a reliable, convenient mobile PC.

This manual contains general information and instructions for use with Professional Notebooks from Fujitsu Technology Solutions. Among other things, this operating manual will tell you how to get your notebook ready for use and how to use its different components.

A square icon with a black border containing a lowercase letter 'i' in a serif font, representing information.





As the manual is intended to cover a whole range of models, it is possible that your notebook may not be equipped with all of the components and modules which are described here.

Information which is specific to your device - such as the Device Overview and the Technical Data - can be found the EasyGuide which is supplied together with your notebook.

Further information about your notebook can also be found:

- in the EasyGuide for your notebook which is supplied on the enclosed "Drivers & Utilities" CD/DVD (device-specific information).
- in the hard copy "Safety" manual.
- in the "Wireless LAN" manual on the "Drivers & Utilities" CD/DVD.
- in the documentation of the operating system
- in the information files (e.g. *.TXT, *.DOC, *.WRI, *.HLP, *.PDF)

Notational conventions

	<p>Pay particular attention to text marked with this symbol. Failure to observe these warnings could pose a risk to health, damage the device or lead to loss of data. The warranty will be invalidated if the device becomes defective through failure to observe these warnings.</p>
	<p>Indicates important information for the proper use of the device.</p>
	<p>Indicates an activity that must be performed</p>
	<p>Indicates a result</p>
<p>This font</p>	<p>indicates data entered using the keyboard in a program dialogue or command line, e.g. your password ((Name123) or a command used to start a program (start.exe)</p>
<p>This font</p>	<p>indicates information that is displayed on the screen by a program, e.g.: Installation is complete.</p>
<p><i>This font</i></p>	<p>indicates</p> <ul style="list-style-type: none"> • terms and texts used in a software interface, e.g.: Click on <i>Save</i> • names of programs or files, e.g. <i>Windows</i> or <i>setup.exe</i>.
<p>"This font"</p>	<p>indicates</p> <ul style="list-style-type: none"> • cross-references to another section, e.g. "Safety information" • cross-references to an external source, e.g. a web address: For more information, go to "http://ts.fujitsu.com" • Names of CDs, DVDs and titles or designations of other materials, e.g.: "CD/DVD Drivers & Utilities" or "Safety" Manual
<p>Abc</p>	<p>indicates a key on the keyboard, e.g: F10</p>
<p>This font</p>	<p>indicates terms and texts that are emphasised or highlighted, e.g.: Do not switch off the device</p>

Important notes

This chapter contains essential safety information which must be followed when working with your notebook. Other notes also provide useful information which will help you with your notebook.

safety information



Pay attention to the information provided in the "Safety" manual and in the following safety notes.

Observe the sections in the manual marked with the symbol on the left.

- When connecting and disconnecting cables, observe the relevant notes in this operating manual.
- When cleaning the device, please observe the relevant notes in ["Cleaning the notebook", Page 5](#).
- If you have a device with a radio component, also observe the information in the "Safety" manual and in section ["Additional safety notes for devices with radio components", Page 3](#).

This notebook complies with the relevant safety regulations for data processing equipment. If you have questions about using your notebook in a particular area, please contact your sales outlet or our Hotline/Help Desk.

Additional safety notes for devices with radio components

If a radio component (Wireless LAN, Bluetooth or UMTS) is integrated in your notebook, you must be sure to observe the following safety notes when using your notebook:

- Switch off the radio components (the ON/OFF switch must be in the "OFF" position), when you are at an airport or driving in a car.
- Switch off the radio components (the ON/OFF switch must be in the "OFF" position), when you are in a hospital, an operating theatre or near electronic medical equipment. The transmitted radio waves can impair the operation of medical devices.
- Switch off the radio components (the ON/OFF switch must be in the "OFF" position), when you take the device close to flammable gases or into hazardous environments (e.g. petrol station, paintshops), as the transmitted radio waves can cause an explosion or a fire.

Travelling with your notebook

Please follow these guidelines when travelling with your notebook.

Before you travel

- Back up important data stored on your hard disk.
- Switch off the radio component (Wireless LAN/Bluetooth/UMTS) for data security reasons. Data traffic on a wireless connection can be intercepted by unauthorised third parties.



Information on activating data encryption is provided in the documentation for your wireless component.

- If you wish to use your notebook during a flight, first check with the flight attendants if it is OK to do so.

When travelling in other countries

- If you are travelling abroad, check that the mains adapter can be operated with the local mains voltage. If this is not the case, obtain the appropriate mains adapter for your notebook. Do not use any other voltage converter!
- Check whether the local voltage and the specifications of the power cable are compatible. If this is not the case, buy a power cable that matches the local conditions. Do not use a connection adapter for electrical devices to connect the notebook.
- Enquire with the corresponding government office of the country you will be travelling in as to whether you may operate the radio component integrated in your notebook there (also see "[CE marking](#)", [Page 66](#)).
- If you use a modem, incompatibilities with the local telecommunications system may result. This may result in poor performance, or the modem will not work at all. You may require a country-specific telephone adapter (available as an accessory).

Transporting your notebook

- Remove all data carriers (e.g. CD) from the drives.
- Switch off the notebook with the ON/OFF button (see EasyGuide, "Switching off the notebook").
- Unplug the mains adapter and all external devices from the power socket.
- Disconnect the mains adapter cable and the data cables for all external devices.
- Close the connector covers.
- Close the LCD screen so that it locks into place.
- If the device needs to be shipped, use the original packaging or other suitable packaging to protect it from damage caused by mishandling.
- To protect the notebook against damaging jolts and bumps, use a notebook carrying case to transport your notebook.
You will find the current range on the Internet under "<http://ts.fujitsu.com/accessories>".
- Protect the notebook from severe shocks and extreme temperatures (e.g. direct sunlight in a car).

Cleaning the notebook

- ▶ Switch the notebook off.
- ▶ Unplug the mains plug of the mains adapter from the mains socket.



Do not clean any interior parts yourself; leave this job to a service technician.

Only use cleaning products designed for computers. Normal household cleaners and polishes can damage the markings on the keyboard and the device, the paintwork or the notebook itself.

Ensure that no liquid enters the notebook.

- ▶ Remove the battery - refer to the section entitled "Battery" in the EasyGuide.
- ↳ You can clean the casing and fingerprint sensor with a dry cloth. If particularly dirty, use a cloth which has been moistened in mild domestic detergent and then carefully wrung out.
To clean the keyboard and the touchpad, you can use disinfectant wipes.
Wipe the LCD screen with a soft, moistened cloth.

Preparing the notebook for use



Please read and observe the relevant notes in ["Important notes", Page 3](#) and in the manual for your radio components.

You must charge the battery and install the application programmes before you can work with the notebook. The operating system and drivers required are preinstalled (only with Windows operating systems).

When not plugged into a mains outlet, the notebook runs on its built-in battery. You can increase the battery's life by enabling the system's energy saving functions.

If you use the notebook in a normal office situation, run it from the mains using the mains adapter.

Please refer to ["Connecting external devices", Page 46](#) for instructions on how to connect external devices such as a mouse and a printer to the notebook.

Unpacking and checking the delivery

- ▶ Unpack all the individual parts.
- ▶ Check the delivery for damage incurred during transportation.
- ▶ Check whether the delivery conforms to the details in the delivery note.



Should you discover that the delivery does not correspond to the delivery note, notify your local sales outlet immediately.

Do not discard the original packing material of the devices. You may need the packaging in the future if you need to transport your device.

Selecting the location



Select a suitable location for the notebook before setting it up. Consider the following points when selecting a location:

- Never place the notebook on a soft surface (e.g. carpeting, upholstered furniture, bed). This can block the air vents and cause overheating and damage.
- Do not place the notebook on your legs for a long period of time. The underside of the notebook heats up during normal operation. Prolonged contact with the skin can become unpleasant or may even cause burns.
- Place the notebook on a stable, flat, nonslippery surface. Please note that the rubber feet may mark certain types of surfaces.
- Never place the notebook and the mains adapter on a heat-sensitive surface.

Mains adapter connecting



Please read the information in ["Selecting the location", Page 6](#).

The power cable supplied conforms to the requirements of the country in which you purchased your notebook. Make sure that the power cable is approved for use in the country in which you intend to use it.

The mains adapter's power cable must only be connected to a mains socket if the notebook is connected to the mains adapter.

Do not use the mains adapter for other notebooks or devices.

Do not use a mains adapter that is not specially intended for this notebook.

Make sure that the rated current of the mains adapter is not higher than that of the mains supply to which you connect it (see "Technical Data" in the EasyGuide).

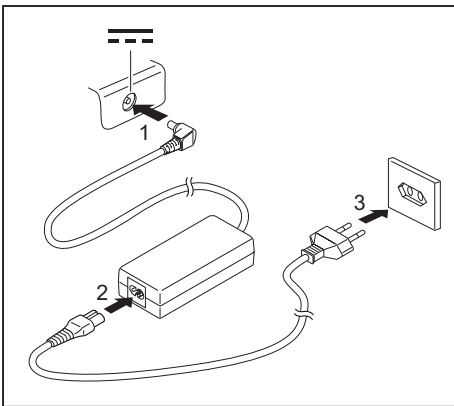

- ▶ Connect the mains adapter cable (1) to the DC jack (DC IN) on the notebook.
- ▶ Connect the power cable (2) into the mains adapter.
- ▶ Plug the power cable (3) into a mains outlet.

↳ The battery will charge.



The meanings of the various displays can be found in the EasyGuide.

Switching the notebook on for the first time



When you switch your notebook on for the first time, the supplied software is installed and configured. Due to the fact that this installation procedure must not be interrupted, you should set aside enough time for it to be fully completed and connect the notebook to the mains outlet using the mains adapter.

During installation, the notebook must only be rebooted when you are requested to do so!

- ▶ Switch the notebook on (refer to the section entitled "Switching on the notebook" in the EasyGuide).
- ↳ The installation process will start automatically.
- ▶ During installation, follow the on-screen instructions.
- ↳ Consult the operating system manual if anything is unclear about the requested input data.



The "Drivers & Utilities" CD/DVD or the Internet at: ["http://ts.fujitsu.com/support"](http://ts.fujitsu.com/support), provides further information on the system, drivers, utilities, updates, manuals etc.

Using your notebook

This chapter describes the basics for operating your notebook.

Please refer to "[Connecting external devices](#)", [Page 46](#) for instructions on how to connect external devices such as a mouse and a printer to the notebook.



Please refer to the notes in the chapter "[Important notes](#)", [Page 3](#).



An overview of the device can be found in the EasyGuide.

Keyboard



The keyboard of your notebook is subject to continuous wear through normal use. The key markings are especially prone to wear. The key markings are liable to wear away over the life of the notebook.

The keyboard has been designed to provide all the functions of an enhanced keyboard. Some enhanced keyboard functions are mapped with key combinations.

The following description of keys and key combinations refers to Windows.

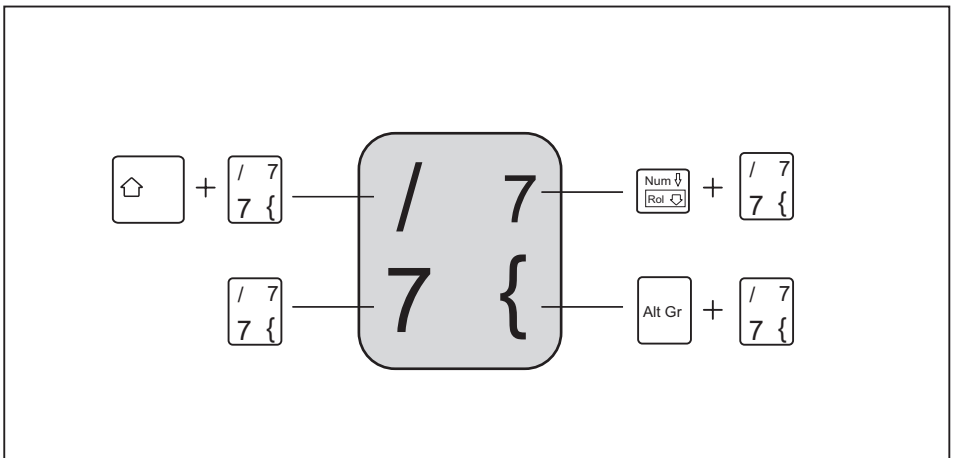



Backspace key

The Backspace key deletes the character to the left of the cursor.



Tab key

The Tab key moves the cursor to the next tab stop.



Enter key (return)

The Enter key terminates a command line. The command you have entered is executed when you press this key.



Caps Lock key

The Caps Lock key activates uppercase mode (Caps Lock indicator lit). The Caps Lock function causes all the characters you type to appear in uppercase. In the case of overlay keys, the character printed on the upper left of the key appears when that key is pressed. To cancel the Caps Lock function, simply press the Caps Lock key again.



Shift key

The Shift key causes uppercase characters to appear. In the case of overlay keys, the character printed on the upper left of the key appears when that key is pressed.



Alt Gr key

The **Alt Gr** key allows you to type the characters printed on the lower right of the key (e.g. the "!" symbol on the **7** key on a German keyboard).



Fn button

The **Fn** key enables the special functions indicated on overlay keys (refer to "Key combinations" in the EasyGuide).

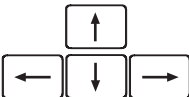

Cursor keys

The cursor keys move the cursor in the direction of the arrow, i.e. up, down, left, or right.



Pause key

The **Pause** key temporarily suspends the screen output. Output resumes when you press any other key.



Start button (Windows XP)

The Start key opens the Windows Start menu.

**Start button (Windows Vista)**

The Start key opens the Windows Start menu.

**Menu key**

The Menu key invokes the menu for the marked item.

Virtual numeric keypad

The keyboard of your notebook does not have a separate number block. To provide the convenience of a numeric keypad, your keyboard is equipped with a virtual numeric keypad. The special keys of the virtual numeric keypad are recognisable by the numbers and symbols printed in the upper right corner of each key. If you have switched on the virtual numeric keypad, you can output the characters shown on the upper right of the keys.

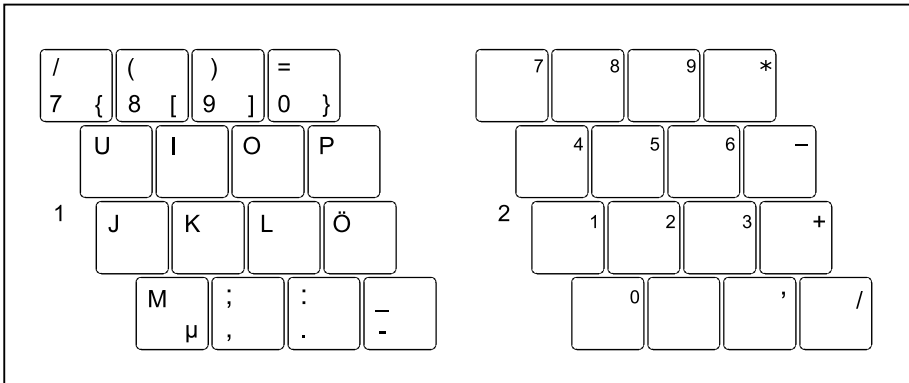

1 = Characters enabled when Num Lock indicator is not lit (refer to the EasyGuide for more information).

2 = Characters enabled when Num Lock indicator is lit (refer to the EasyGuide for more information).

TouchStick, Touchpad, TouchStick and Touchpad buttons

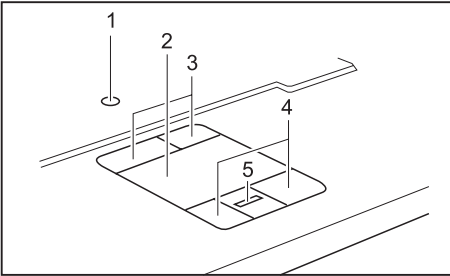

Depending on your particular model, your notebook may be equipped with a TouchStick (1) and a Touchpad (2) for the mouse controls.

Instead of mouse keys, your notebook has TouchStick buttons (3) and Touchpad buttons (4). TouchStick buttons and Touchpad buttons offer the same functions.

Depending on the model, your notebook may also have a scroll button (5) which makes it easier for you to scroll through documents.

- 1 = TouchStick (optional)
- 2 = Touchpad
- 3 = TouchStick buttons (optional)
- 4 = Touchpad buttons
- 5 = Scroll button or fingerprint sensor (optional)



Keep the touchpad clean. Protect it from dirt, liquids, and grease.

Do not use the touchpad if your fingers are dirty.

Do not rest heavy objects on the TouchStick, Touchpad, TouchStick buttons or Touchpad buttons.

Using Touchpad buttons

Moving the pointer

▶ Move your finger on the Touchpad.

or

▶ Press down gently with your finger on the TouchStick. If you want to move the pointer to the left for example, press down gently on the left side of the TouchStick.

↳ The pointer will move accordingly.

Selecting an item

▶ Move the pointer to the item you wish to select.

▶ Tap the Touchpad once or press the left-hand TouchStick/Touchpad button once.

↳ The item is selected.

Executing a command

▶ Move the pointer to the field you wish to select.

▶ Tap the Touchpad twice or press the left TouchStick/Touchpad button twice.

↳ The command is executed.

Dragging an object

▶ Move the pointer to the item you wish to select.

▶ Select the desired object and hold down the left TouchStick/Touchpad button.

▶ Drag the object to the desired position.

▶ Lift your finger from the touchpad.

or

▶ Lift your finger from the TouchStick.

↳ The item will be moved.

Scrolling up

▶ Press the upper side of the scroll button (if present) to scroll up.

↳ The information/texts above the display area appear.

Scrolling down

▶ Press the lower side of the scroll button (if present) to scroll down.

↳ The information/texts below the display area appear.

LCD screen

Information on LCD screen

High-quality TFT displays with especially bright background lighting are installed in notebooks from Fujitsu Technology Solutions GmbH. For technical reasons, TFT monitors are manufactured for a specific resolution. An optimal, clear picture can only be ensured with the correct resolution intended for the relevant TFT monitor. A monitor resolution which differs from the specification can result in an unclear picture.

The monitor resolution is understood to be the number of horizontal and vertical pixels (i.e. picture elements) which make up the monitor display. For example, "UXGA" stands for 1600 x 1200 pixels. Each pixel consists of three so-called subpixels of the colours red, green and blue. As a result, a UXGA monitor consists of $1600 \times 1200 \times 3 = 5.760.000$ subpixels.

"Square" resolutions

Screen resolutions	Number of pixels
XGA	1024 x 768
SXGA	1280 x 1024
SXGA+	1400 x 1050
UXGA	1600 x 1200

Wide resolutions:

Screen resolutions	Number of pixels
WXGA	1280 x 768
WXGA+	1440 x 900
WSXGA+ (Wide SXGA plus)	1680 x 1050
WUXGA	1920 x 1200

The correct screen resolution for your notebook can be found under "Technical Data" in the EasyGuide.

Permanently unlit or lit pixels

The standard of production techniques today cannot guarantee an absolutely fault-free screen display. A few isolated constant lit or unlit pixels may be present. The maximum permitted number of pixels faults is stipulated in the strict international standard ISO 13406-2 (Class II).

Example:

A 15" LCD screen monitor with a resolution of 1024 x 768 has 1024 x 768 = 786432 pixels. Each pixel consists of three subpixels (red, green and blue), so there are almost 2.4 million subpixels in total. According to ISO 13406-2 (Class II), a maximum of 4 pixels and 5 subpixels may be defective, i.e. a total of 17 defective subpixels. That is approx. 0.0007 % of the entire set of subpixels!

Pixel	A pixel consists of 3 subpixels, normally red, green and blue. A pixel is the smallest element that can be generated by complete functionality of the display.
Subpixel	A subpixel is a separately addressable internal structure within a pixel that enhances the pixel function.
Cluster	A cluster contains two or more defective pixels or subpixels in a 5 x 5 pixel block.

Background lighting

TFT monitors are operated with background lighting. The luminosity of the background lighting can decrease during the period of use of the notebook. However, you can set the brightness of your monitor individually.

Screen settings

Adjusting the resolution (under Windows XP)

You can change the screen resolution under *Start – (Settings) - Control Panel - Display - Settings* and then selecting from the *Resolution* field.

Adjusting the resolution (under Windows Vista)

You can change the screen resolution under *Start – (Settings) – Control Panel – Appearance and Personalization – Personalization: Adjust screen resolution*

Selecting the font size (under Windows XP)

Under *Start – (Settings) - Control Panel - Display - Appearance and Themes* you can choose between a larger and a smaller font in the *Font size* field.

Selecting the font size (under Windows Vista)

You can choose between a larger and a smaller font.

- ▶ Right-click on the desktop. Configure the settings as desired under *Personalization – Adjust font size (DPI)* (in the left-hand menu selection) – *Continue* .

or

- ▶ Enter your settings by clicking *Start – (Settings) – Control Panel – Appearance and Personalization – Personalization – Adjust Font Size (DPI)* (in the left pane) – *Continue*.

Adjusting the brightness of the display

You can adjust the brightness of your LCD screen with the aid of certain key combinations. More information about the device-specific key combinations can be found in "Key combinations" in the EasyGuide.

Synchronising the display on the LCD screen and an external monitor

Your notebook supports simultaneous display on the LCD screen and an external monitor. If the picture does not appear correctly on the LCD screen, press the key combination for the function (refer to "Key combinations" in the EasyGuide) or switch the external monitor off and then back on again. This achieves good picture synchronisation.

Adjusting the speed of the mouse pointer (under Windows XP)

Under *Start - (Settings) - Control Panel - Mouse - Pointer Options* you can change the pointer speed in the *Movement* field.

Battery

The battery supplies your notebook with the power it needs during mobile use. You can make a battery charge last longer by enabling the system's power management features, see "[Energy saving functions](#)", [Page 50](#).

The charge level of the battery is indicated with the battery symbol in the status indicator panel (refer also to the EasyGuide for more information about the status indicators). When you switch on the notebook, it takes a few seconds before the battery status is displayed.

The life of the battery is dependent on its proper storage, the number of charging/discharging cycles and the operating temperature of the notebook.

Charging, caring for and maintaining the battery



Only use rechargeable batteries approved by Fujitsu Technology Solutions for your notebook.

Take care not to drop batteries or otherwise damage their casing (fire risk).

If rechargeable batteries develop a fault please stop using them immediately.

Do not touch the contacts of batteries.

The plus and minus terminals of a battery must never be connected together. Batteries must be disposed of according to the local regulations for special waste.

Battery charging

You can charge the battery by connecting the notebook to the mains adapter. The battery can only be recharged if the ambient temperature of the notebook falls within the permitted temperature range. The time taken to charge the battery depends on its usage. Information on the battery charging time can be found under "Technical Data" in the EasyGuide.

You can increase the life of your battery by allowing it to fully discharge before recharging it again. To do this, leave your notebook turned on when it is operated with the battery. Once the battery is running low you will hear a warning alarm. If you do not connect the mains adapter within five minutes of the warning alarm described above, your notebook will automatically switch off.



Windows XP:

You can set the power-management features for your notebook under *Start - (Settings) - Control Panel - Power Options*.

Windows Vista:

You can set the power-management features for your notebook under *Start - (Settings) - Control Panel - Mobile PC - Power Options*.

Battery storing

Keep the battery pack in a dry environment between 0 °C and +30 °C. The lower the temperature at which the batteries are stored, the lower the rate of self-discharge.

If you will be storing batteries for a longer period (longer than two months), the battery charge level should be approx. 30 %. To prevent total discharge, check the charging level of the batteries at regular intervals.



If you do not use batteries for long periods, remove them from the device.
Never store batteries in the unit.

Monitoring the battery charging level

The charge level of the battery is indicated with the battery charging indicator (refer also to the EasyGuide for more information about the status indicators). When you switch on the device, it takes a few seconds before the battery status is displayed.

Windows includes a "Current charge status indicator" for monitoring the battery capacity. This can be activated under *Start - (Settings) - Control Panel - Power Options* (Windows XP) or *Start - (Settings) - Control Panel - Mobile PC - Power Options* (Windows Vista). The indicator is then displayed in the task bar as a battery symbol. When you place the mouse pointer on the battery symbol, the system displays the battery status. Further information may be found in the operating system help.

Modules (device-dependent)

The design of your notebook enables the flexible use of notebook batteries and drives. More information about the available modules can be found under "Technical Data" in the EasyGuide.



The position of the module and the ejection mechanism varies depending on the particular device. Below you will find two descriptions for the removal and installation of modules. Please choose the matching description for your device.



Only use modules designed for your notebook.

Do not use force when installing or removing the module.

Make sure that no foreign objects enter the module bay.



You can replace modules during operation. This means you do not need to switch off the notebook.

To replace a module, simply click on the corresponding icon in the task bar and then on *Exit* or *Select - Exit*.

Then you can simply remove the module.

Removing a module

Device variant 1

- ▶ Place the notebook on a flat surface.
Use the corresponding icon in the task bar to stop the module:
- ▶ Left-click on the icon.
- ▶ Select the module you want to stop and remove.
- ▶ Press the Enter key.
- ↳ Wait for the dialogue box which tells you that it is now safe to remove the module.

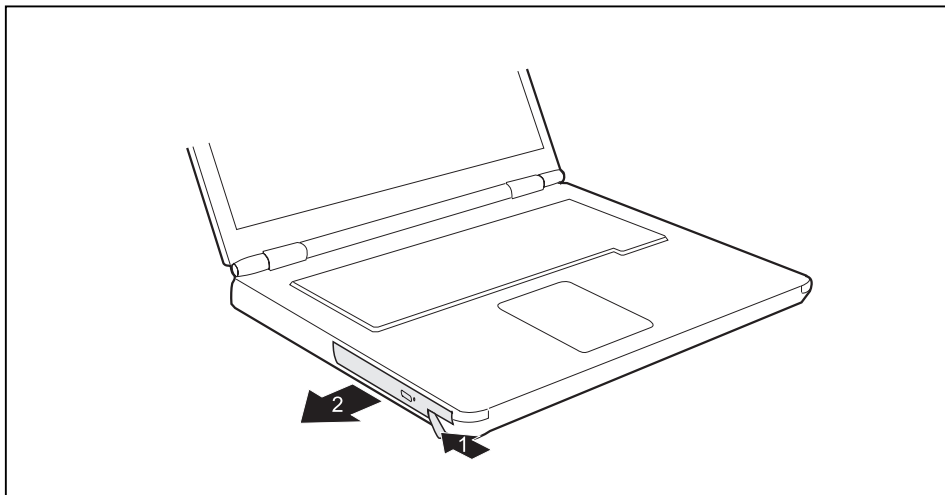

- ▶ Carefully pull the eject lever in the direction of the arrow up to the stop (1).
- ↳ The module now extends somewhat beyond the casing.
- ▶ Pull the module out of the module bay (2).

Device variant 2

- ▶ Place the notebook on a flat surface.
- Use the corresponding icon in the task bar to stop the module:
- ▶ Left-click on the icon.
- ▶ Select the module you want to stop and remove.
- ▶ Press the Enter key.
- ↳ Wait for the dialogue box which tells you that it is now safe to remove the module.

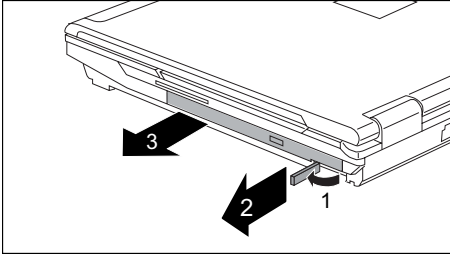

- ▶ Fold the module lever in the direction of the arrow (1) and hold it in place.
- ▶ Pull the module lever in the direction of the arrow (2).
- ↳ The module is unlocked.
- ▶ Carefully pull the module out of the notebook (3).

Installing a module

Device variant 1

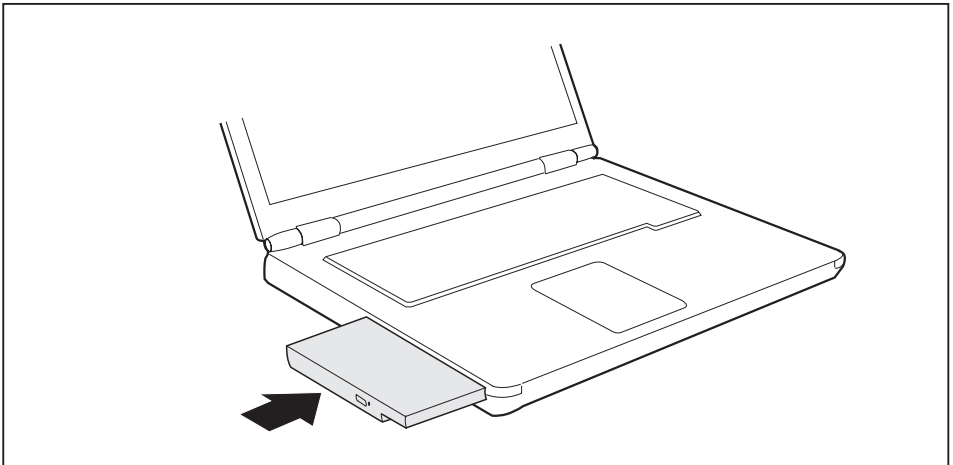

- ▶ Place the module into the module bay so that the contacts enter first.
- ▶ Push the module into the module bay until you feel it locking into place.

Device variant 2

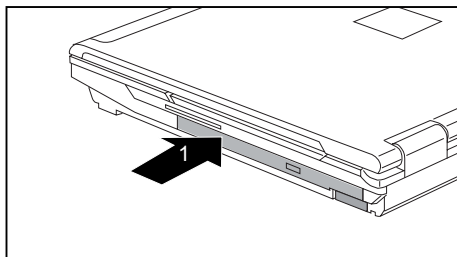

- ▶ Slide the module in the direction of the arrow into the notebook (1) until you feel it lock in place.

Optical drive

You can replace your optical drive with another module (e.g. drive or battery) (see ["Modules \(device-dependent\)", Page 19](#)).



This product contains a light emitting diode, classified in accordance with IEC 8251:1993: LASER CLASS 1, and must therefore not be opened.

Handling CD/DVDs

Observe the following guidelines when handling CD/DVDs:

- Avoid touching the surface of a CD/DVD. Hold CDs/DVDs by their edges!
- Always store CDs/DVDs in their cases. This will protect them from dust, scratches and other damage.
- Protect your CDs/DVDs from dust, mechanical vibration and direct sunlight!
- Avoid storing a CD/DVD in areas subject to high temperatures or humidity.

You may use both 8-cm and 12-cm CDs/DVDs in the optical drive.

When using CD/DVDs of poor quality vibrations and reading errors may occur.

CD/DVD indicator

The CD/DVD indicator flashes when a CD/DVD is inserted. The indicator goes out when the drive is ready for reading. The indicator lights up when the drive is being accessed. You may only remove the CD/DVD when the indicator is dark.



If the CD/DVD indicator does not go out after inserting a CD/DVD, but instead continues to flash, this means that the drive cannot access the data carrier.

Either the CD/DVD is damaged or dirty or you are using a data carrier that the drive cannot read.

Inserting or removing a CD/DVD

The notebook must be switched on.

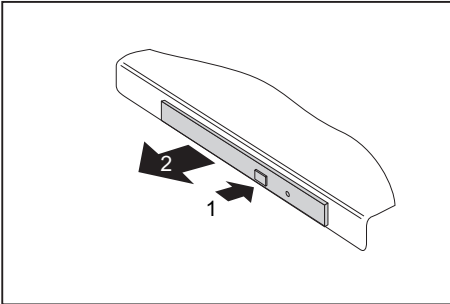

- ▶ Push the insert/eject button (1).
- ↳ The drive tray will open.
- ▶ Gently pull the drive tray (2) completely out.

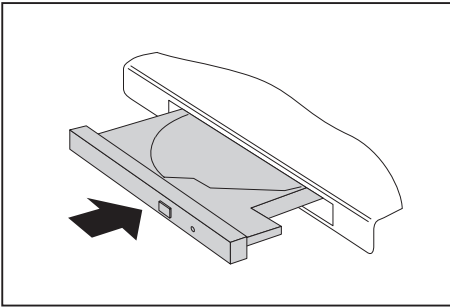

- ▶ Place the CD/DVD in the drive tray with the label facing upwards.

or

- ▶ Take out an inserted CD/DVD.
- ▶ Push in the drive tray until you feel it lock into place.

Manual removal (emergency removal)

In the event of a power failure or damage to the drive it may be necessary to manually remove the CD/DVD.

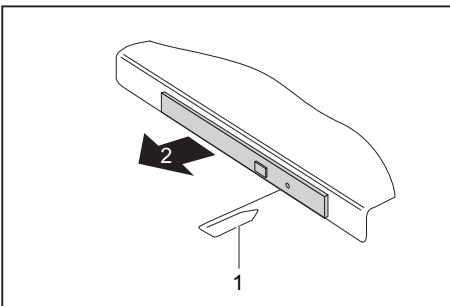

- ▶ Switch your notebook off.
- ▶ Push a pen or a piece of wire (such as a paperclip) firmly into the opening (1).
- ↳ The drive tray is ejected. You can now pull the drive tray (2) out of the drive.

Memory cards

Depending on the particular model, your notebook may be equipped with a memory card slot. The memory card slot permits the operation of a "Secure Digital" (SD) memory card.



Please read the documentation supplied with the memory card for any special instructions.

Memory card inserting

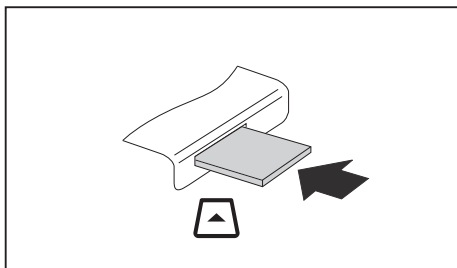

- ▶ Carefully push the memory card into the slot. The label should be facing upward.
- ↳ The memory card may protrude by one to several millimetres (depending on the memory card type).

Removing a memory Card

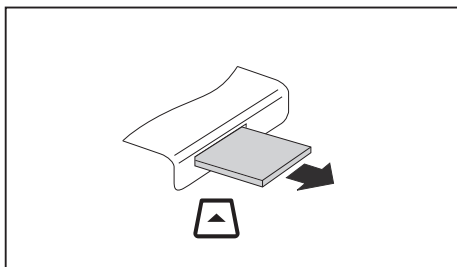

- ▶ Press on the edge of the memory card so that the memory card jumps out of the slot slightly.
- ▶ Pull the memory card out of the notebook.

PC cards and ExpressCards

An ExpressCard slot enables operation of an ExpressCard/34 or ExpressCard/54.

A PC card slot enables the notebook to operate one type I or type II PC card.



Please read the documentation on the PC card and/or on the ExpressCard and follow the manufacturer's instructions.

Never use force when installing or removing a PC card or an ExpressCard.



The ExpressCard slot and the PC card slot can be protected with placeholders, which you must remove before using the slots.

Keep the placeholder in a safe place. When you remove the PC card or ExpressCard you should also refit the placeholder in the empty slot. This prevents foreign matter from getting into the slot.

Please see the documentation relating to the card for driver installation instructions.

You should also read the help files on the supplied CD, the information provided with the drivers for the card, or the information provided with the operating system (e. g. *Help and Support Center* in Windows XP).

Depending on the model, your notebook has a PC card and ExpressCard eject button. You can push the card slot eject button into the notebook casing. Press the eject button until it snaps in. This prevents the card from being ejected accidentally.

Inserting a card

Devices with an eject button

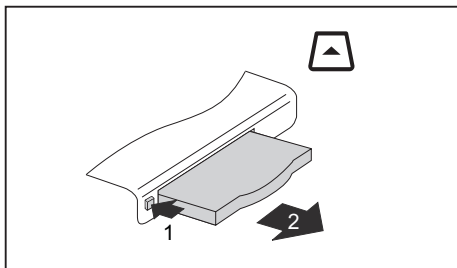

- ▶ If the eject button is lowered, you must first cause the eject button to release from the notebook casing. To do this, press the eject button until it pops out. Press the eject button (1) to make the placeholder for the card protrude from the notebook's case.
- ▶ Pull the card placeholder out of the slot (2).

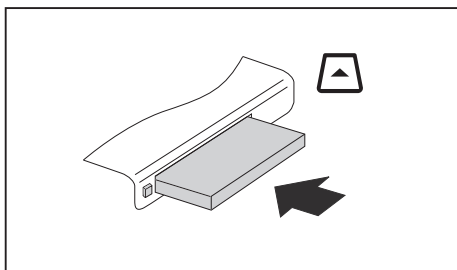

- ▶ Insert the card into the slot guide with the connection contacts first.
- ▶ Gently push the card into the slot until you feel it click into place.

Devices without an eject button

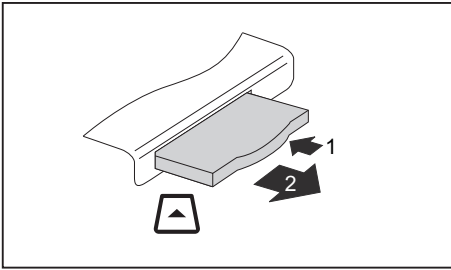

- ▶ Press the edge of the placeholder (1) to make the card placeholder protrude from the notebook's case.
- ▶ Pull the card placeholder out of the slot (2).

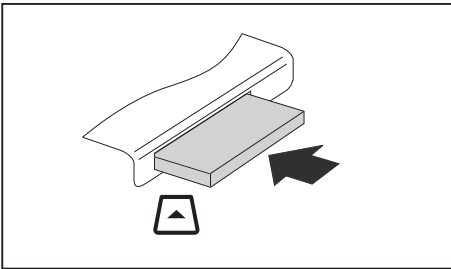

- ▶ Insert the card into the slot guide with the connection contacts first.
- ▶ Gently push the card into the slot until you feel it click into place.

Device with card release

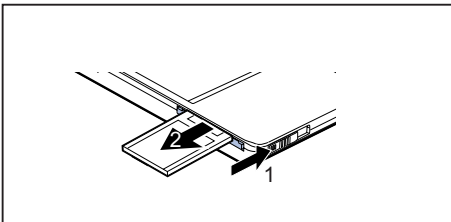

- ▶ Press the card release in the direction of the arrow (1) so that the card protrudes a little from the notebook.
- ▶ Pull the card (2) out of the slot.

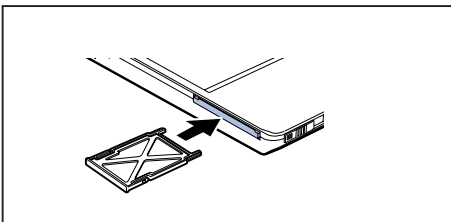

- ▶ Insert the card placeholder into the slot guide.
- ▶ Gently slide the card placeholder into the slot until you feel it click into place.

Removing the card

You can stop the ExpressCard, using the corresponding symbol in the task bar:

- ▶ Left-click on the icon.
- ▶ Select the card you want to stop and remove.
- ▶ Press the Enter key.
- ↳ Wait for the dialogue box which tells you that it is now safe to remove the card.

Devices with an eject button

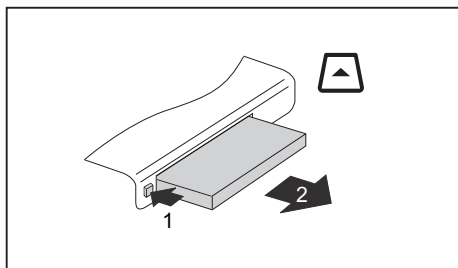

- ▶ If the eject button is lowered, you must first cause the eject button to release from the notebook casing. To do this, press the eject button until it pops out. Press the eject button (1) so that the card protrudes a little from the notebook.
- ▶ Pull the card out of the slot (2).

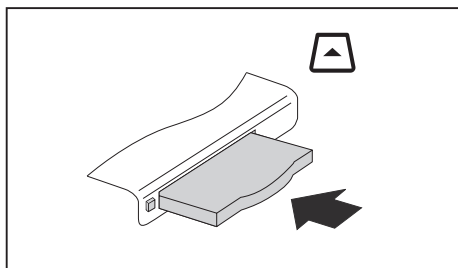

- ▶ Insert the card placeholder into the slot guide.
- ▶ Gently slide the card placeholder into the slot until you feel it click into place.

Devices without an eject button

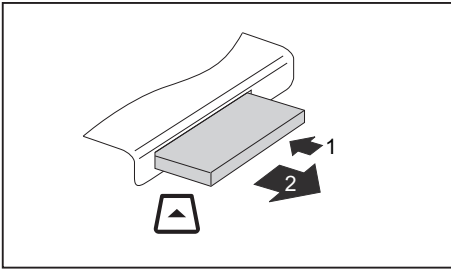

- ▶ Press the edge of the card (1) so that the card protrudes a little from the notebook.
- ▶ Pull the card out of the slot (2).

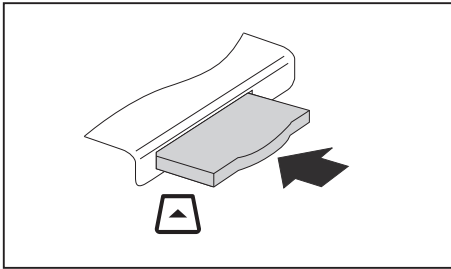

- ▶ Insert the card placeholder into the slot guide.
- ▶ Gently slide the card placeholder into the slot until you feel it click into place.

Device with card release

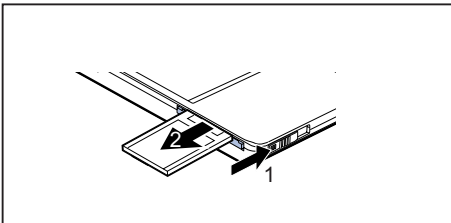

- ▶ Press the card release in the direction of the arrow (1) so that the card protrudes a little from the notebook.
- ▶ Pull the card (2) out of the slot.

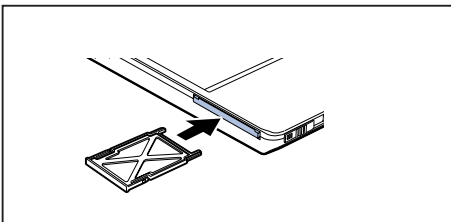

- ▶ Insert the card placeholder into the slot guide.
- ▶ Gently slide the card placeholder into the slot until you feel it click into place.

Integrated 56k modem (optional)

The integrated 56k modem supports all data communication applications, such as:

- Modem operation: High-speed downloads at up to 56,000 bit/s (V.9x). Backwards-compatible to V.34 modems.
- Fax operation: Transmitting and receiving at up to 14,400 bit/s
- Simple country adaptation with programme

The modem complies with the EU Directive 91/263/EEC (Telecommunications terminal equipment directive) and has been checked in agreement with the guideline TBR-21.

The modem can be operated in the following countries:

- Multifrequency (MFC) dialling: Belgium, Denmark, Germany, Finland, France, Greece, United Kingdom, Ireland, Iceland, Italy, Luxemburg, the Netherlands, Norway, Austria, Portugal, Sweden, Switzerland and Spain.
- Pulse dialling: Belgium, France, Italy and the Netherlands
- Also in: Poland, Slovenia, South Africa and Hungary

Connecting notebook modem to telephone wall socket

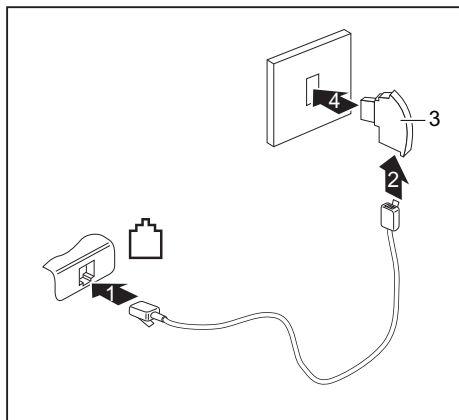

- ▶ If necessary, connect the modem cable provided to the optionally available country-specific telephone adapter.
- ▶ Connect the modem cable to the modem port of the notebook (1).
- ▶ Plug the modem cable (2) into the country-specific telephone adapter (3).
- ▶ Connect the modem cable to your telephone wall socket (4).



Please note that the telephone line is busy and that you cannot use your telephone if the modem cable is plugged into the telephone wall socket. Pull the modem cable out of the telephone socket after you have finished your internet session or the fax mode and reconnect the telephone cable.

Connecting the notebook to a LAN

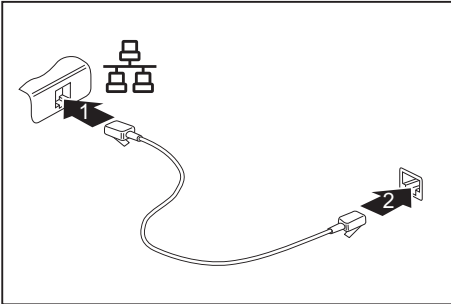

- ▶ Connect the LAN cable to the notebook's LAN port (1).
- ▶ Connect the LAN cable to your network connector (2).

Security functions

Your device enables you to protect your system and personal data in a number of ways against unauthorised access. By combining these options, you can achieve maximum protection for your system.

In this chapter you will learn which security functions your device is equipped with, which advantages these functions offer you and how to configure and use them.



Bear in mind that improper use of security functions will mean that you will also be unable to access your system and your data. Therefore, please note the following information:

- Back up your data on external data carriers at regular intervals.
- Some security functions need you to choose passwords. Please be sure to note these passwords, as otherwise you will no longer be able to access your system. We recommend that you make a note of the passwords and keep them in a safe place. If you lose both the user and the admin passwords you will need to contact our help desk. You will find the telephone numbers on the help desk list supplied or on the Internet under "<http://ts.fujitsu.com/support/>". Passwords are not covered by your warranty and a charge will be made for assistance.

Brief overview of security functions

Security functions	Type of protection	Preparation
Kensington Lock	Mechanical	Fitting and locking the Kensington MicroSaver (accessory)
Fingerprint sensor (device-dependent)	Biometric	Installing the supplied fingerprint software
BIOS password protection	Password protection for <i>BIOS Setup</i> , operating system and hard disk with supervisor and user password. The passwords consist of a maximum of eight alphanumeric characters.	Specify at least one supervisor password in the <i>BIOS Setup</i> and activate the password protection for the operating system and hard disk as desired.
Boot from Removable Media	Prevents unauthorised booting of an operating system from external media (e.g. USB stick, USB CD-ROM drive etc.)	In the BIOS Setup, go to the <i>Security</i> menu and edit the option <i>Boot from Removable Media</i> .
Owner Information (device-dependent)	Displays Help Desk or Owner Information during the booting process	In the BIOS Setup go to the <i>Security</i> menu and edit the option <i>Owner Information</i> .
Virus Warning (device-dependent)	This checks the boot sectors of the hard disk drive to see if any changes have been made since the previous system start-up.	In the BIOS Setup go to the <i>Security</i> menu and edit the option <i>Virus Warning</i> .
SmartCard reader (device-dependent)	PIN and SmartCard protection for operating system	Install the corresponding software, e.g. <i>SmartCase Logon+</i> (accessory). Specify a password when using the <i>SmartCase Logon+</i> software.
Trusted Platform Module (device-dependent)	Identification and authentication of the notebook	Defining a supervisor password in the <i>BIOS Setup</i> and enabling the TPM (<i>Security Chip</i>)

Using Kensington Lock

The notebook has a Kensington Lock device for the Kensington MicroSaver. With the Kensington MicroSaver, a sturdy steel cable, you can protect your notebook and Port Replicator from theft. The Kensington MicroSaver is available as an accessory.

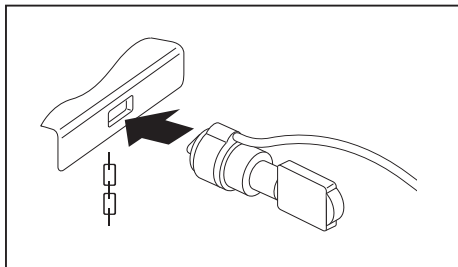

- ▶ Fit the Kensington MicroSaver to the corresponding device on your notebook.

Setting up the fingerprint sensor (device-dependent)

Depending on the model, your notebook is equipped with a fingerprint sensor. The fingerprint sensor can record the image of a fingerprint. With additional fingerprint software, this image can be processed and used instead of a password.

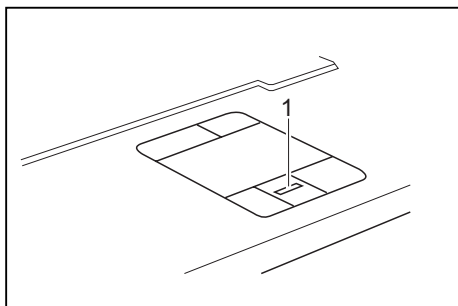

- ▶ Install the fingerprint software from the CD supplied in order to use the fingerprint sensor (1).

Configuring password protection in BIOS Setup



Before using the various options for password protection in the *BIOS Setup* to increase data security, please note the following hints:

- Please make sure that you always remember your passwords, as you will not be able to access your *BIOS Setup* and/or your system any longer if you forget the user password and the supervisor password.
Passwords are not covered by your warranty and a charge will be made for assistance.
- Back up your data on external data carriers at regular intervals



Passwords can be up to eight characters long. You can use all alphanumeric characters and need not distinguish between uppercase and lowercase characters.

Password protection for BIOS Setup (supervisor and user password)

We recommend that you print out the following instructions, as these cannot be displayed while setting the password.

By using both the supervisor and the user password you can prevent unauthorised persons from opening the *BIOS Setup*. The supervisor password gives you access to all functions of the *BIOS Setup*, while the user password only provides some of the functions. You can only set a user password if a supervisor password has already been assigned.



Please refer to section ["Settings in BIOS Setup", Page 52](#) for a description of calling and operating the BIOS Setup.

Setting the supervisor and user password

- ▶ Call up the *BIOS Setup* and select the *Security* menu.
- ▶ Select the *Set Supervisor Password* field and press the Enter key.
- ↳ With *Enter new Password*: you are asked to enter a password.
- ▶ Enter the password and press the Enter key.
- ↳ *Confirm new Password* then appears and you are asked to confirm the password.
- ▶ Enter the password again and press the Enter key.
- ↳ *Setup Notice: Changes have been saved* is displayed to confirm that the new password has been saved.
- ▶ To assign the user password, select the field *Set User Password* and proceed exactly as when configuring the supervisor password.
- ↳ You can exit the *BIOS Setup* once you have finished changing the settings.
- ▶ From the *Exit* menu, choose the option *Exit Saving Changes*.
- ▶ Press the Enter key and select *Yes*.
- ↳ The notebook is rebooted and the new password becomes effective. If you now want to open the BIOS-Setup, you must first enter your supervisor or user password. Please note that you only have access to a few BIOS settings with the user password.

Changing the supervisor or user password



You can only change the supervisor password when you have logged into the *BIOS Setup* with the supervisor password.

- ▶ Call up the *BIOS Setup* again and select the *Security* menu.
- ▶ Highlight the *Set Supervisor Password* or *Set User Password* field and press the Enter key.
- ▶ Enter your current supervisor or user password.
- ▶ Enter the new supervisor or user password.
- ↳ *Confirm new Password* requires you to confirm the password.
- ▶ Enter the password again and press the Enter key.
- ↳ Notice: Changes have been saved provides you with confirmation that the new password has been saved.

Canceling supervisor and user password

To cancel a password (without setting a new password) proceed as follows:

- ▶ Call up the *BIOS Setup* and select the *Security* menu.
- ▶ Highlight the *Set Supervisor Password* or *Set User Password* field and press the Enter key.
- ↳ You will be initially requested to enter the old password by the *Enter current Password* prompt. You will then be requested to enter a new password by the *Enter new Password* prompt.
- ▶ Press the Enter key three times.
- ▶ From the *Exit* menu, choose the option *Exit Saving Changes*.
- ▶ Press the Enter key and select *Yes*.
- ↳ Your notebook will now restart and the password is cancelled. Removing the supervisor password simultaneously deactivates the user password.

Password protection for starting the operating system



With the supervisor password or the user password, which you have assigned in the *BIOS Setup* (see also "Entering supervisor and user password" section), you can also block booting of the operating system.

Activating system protection

- ▶ Call up the *BIOS Setup* and select the *Security* menu.
- ▶ If you have not yet assigned BIOS passwords, you can now specify the supervisor password and the user password if required (refer to "Setting the supervisor and user password").
- ▶ Highlight the *Password on Boot* field and press the Enter key.
- ▶ Select the *Every Boot* option and press the Enter key.
- ↳ You can exit the *BIOS Setup* once you have finished changing the settings.
- ▶ From the *Exit* menu, choose the option *Exit Saving Changes*.
- ▶ Press the Enter key and select *Yes*.
- ↳ The notebook reboots and you are asked to enter your password (the supervisor or user password).

Deactivating system protection

- ▶ Call up the *BIOS Setup* and select the *Security* menu.
- ▶ Highlight the *Password on Boot* field and press the Enter key.
- ▶ Select *Disabled* and press the Enter key.
- ↳ You can exit the *BIOS Setup* once you have finished changing the settings.
- ▶ From the *Exit* menu, choose the option *Exit Saving Changes*.
- ▶ Press the Enter key and select *Yes*.
- ↳ The notebook reboots and there is no longer any password protection for the operating system.

Password protection for the hard disk



The hard disk password prevents unauthorised access to the hard disk drives and is checked internally each time the system is booted. The condition for this is that you have assigned at least the supervisor password.

Activating hard disk protection (LIFEBOOK)

- ▶ Call up the *BIOS Setup* and select the *Security* menu.
- ↳ If you have not assigned BIOS passwords yet, define the supervisor and the user password now, if desired (see "[Setting the supervisor and user password](#)", Page 36).
- ▶ Mark the *Hard Disk Security* field and press the Enter key.
- ▶ In the *Drive0* area mark the *Set Master Password* field and press the Enter key.
- ↳ *Enter new Password:* then appears and you are asked to enter a password.
- ▶ Enter the password and press the Enter key.
- ↳ *Confirm new Password* requires you to confirm the password.
- ▶ Enter the password again and press the Enter key.
- ↳ *Setup Notice: Changes have been saved* is displayed to confirm that the new password has been saved.
- ▶ To assign the password for the second hard disk (*Drive1*), go to the *Drive1* area and select the field *Set Master Password*, then proceed in exactly the same way as for setting up the password for the first hard disk (*Drive0*).
- ↳ The field *Password Entry on Boot* is set to *Enabled* by default. You can exit the *BIOS Setup* once you have finished changing the settings.
- ▶ From the *Exit* menu, choose the option *Exit Saving Changes*.
- ▶ Press the Enter key and select *Yes*.
- ↳ The notebook reboots and your hard disk is now protected with a password. The system will ask you to enter the password when the notebook is restarted again.

Activating the hard disk protection (ESPRIMO Mobile)

- ▶ Call up the *BIOS Setup* and select the *Main* menu.
- ▶ Highlight the *Main HDD* field and press the Enter key.
- ▶ Select the *Change Password* field and press the enter key.
- ▶ Enter a password consisting of 4 to 8 alphanumeric characters.



The system does not distinguish between upper and lower case letters.

- ▶ Press the Enter key.
- ↳ *Confirm new Password* will appear, asking you to confirm the password.
- ▶ Enter the password again and press the Enter key.
- ↳ *Setup Notice: Changes have been saved* is displayed to confirm that the new password has been saved.

The field *Password Entry on Boot* is set to *Enabled* by default.
You can exit the BIOS Setup now if you have finished changing settings.
- ▶ From the *Exit* menu, choose the option *Exit Saving Changes*.
- ▶ Press the Enter key and select *Yes*.
- ↳ The notebook reboots and your hard disk is now protected with a password.

The system will ask you to enter the password when the notebook is restarted again.

Cancelling the hard disk protection (LIFEBOOK)

To cancel a password without setting a new one, proceed as follows:

- ▶ Call up the *BIOS Setup* and select the *Security* menu.
- ▶ Mark the *Hard Disk Security* field and press the Enter key.
- ▶ In the *Drive0* area mark the *Set Master Password* field and press the Enter key.
- ↳ You will be initially requested to enter the old password by the *Enter current Password* prompt.
You will then be requested to enter a new password by the *Enter new Password* prompt.
- ▶ After entering the password, press the Enter key three times.
- ▶ From the *Exit* menu, choose the option *Exit Saving Changes*.
- ▶ Press the Enter key and select *Yes*.
- ↳ The notebook reboots, and password protection for the hard disk is cancelled.
- ▶ To cancel the password for the second hard disk (*Drive1*), go to the *Drive1* area and select the field *Set Master Password*, then proceed in exactly the same way as for cancelling the password for the first hard disk (*Drive0*).

Canceling the hard disk protection (ESPRIMO Mobile)

To cancel a password without setting a new one, proceed as follows:

- ▶ Call up the *BIOS Setup* and select the *Main* menu.
- ▶ Highlight the *Main HDD* field and press the Enter key.
- ▶ Select the *Change Password* field.
- ↳ You will be initially requested to enter the old password by the *Enter current Password* prompt. You will then be requested to enter a new password by the *Enter new Password* prompt.
- ▶ After entering the password, press the Enter key three times.
- ▶ From the *Exit* menu, choose the option *Exit Saving Changes*.
- ▶ Press the Enter key and select *Yes*.
- ↳ The notebook will restart, and the hard disk protection will be cancelled.

Boot from Removable Media

With this BIOS feature you can control unauthorised booting of an operating system from external media (e.g. USB stick, USB CD-ROM drive etc.). Here, we recommend that you set up the hard disk as the first booting device to prevent access to your system from bootable CDs or other media.



The condition for this BIOS feature is that you have assigned at least the supervisor password.

- ▶ Call up the BIOS Setup and select the *Security* menu.
- ▶ Highlight the *Boot from Removable Media* field and press the Enter key.
- ▶ Select the entry *All* (if you want everyone to be allowed to boot) or *Supervisor Only* (if you only want the supervisor to be authorised to do this) and press the Enter key.
- ↳ If you do not want to change any other settings you can exit the BIOS Setup.
- ▶ From the *Exit* menu, choose the option *Exit Saving Changes*.
- ▶ Press the Enter key and select *Yes*.
- ↳ The notebook will restart and the settings will be adopted.

Owner Information (device-dependent)

The BIOS feature *Owner Information* enables you to enter up to 80 characters of text which is displayed in the bottom left corner of the screen before the operating system boots up. You could use this feature for example to put your name and telephone number on the notebook in case it is lost or stolen.



The condition for this BIOS feature is that you have assigned at least the supervisor password.

- ▶ Call up the BIOS Setup and select the *Security* menu.
- ▶ Highlight the *Owner Information* field and press the Enter key.
- ▶ Add the text you would like to enter under *Set Owner Information*.
- ↳ *Setup Notice: Changes have been saved* is displayed to confirm that the text has been saved.
- ▶ From the *Exit* menu, choose the option *Exit Saving Changes*.
- ▶ Press the Enter key and select *Yes*.
- ↳ The notebook will restart and the Owner Information will be adopted.

Virus Warning (device-dependent)

This field checks the boot sectors of the hard disk drive to see if any changes have been made since the previous system start-up. If the boot sector has been changed since the previous system start-up (e.g. new operating system or virus attack), a warning is displayed on the screen. The warning will stay on the screen until you acknowledge the changes by clicking on *Confirm* or until you set the *Virus Warning* function to *Disabled*.



If the boot sectors have been changed and the reason for this is unknown, a programme for finding computer viruses should be loaded.

However, this type of change can also be caused by the boot manager, not just viruses.

This function does not replace proper anti-virus software.

No supervisor password is required to set it up.

- ▶ Call up the BIOS Setup and select the *Security* menu.
- ▶ Highlight the *Virus Warning* field and press the Enter key.
- ▶ Select *Enabled* to activate the *Virus Warning* function.
- ▶ From the *Exit* menu, choose the option *Exit Saving Changes*.
- ▶ Press the Enter key and select *Yes*.
- ↳ The notebook will restart and the settings will be adopted.

SmartCard reader (device-dependent)

SmartCards are not supplied as standard equipment. You can use all SmartCards that comply with the ISO standard 7816-1, -2 or -3. These SmartCards are available from various manufacturers.

With the appropriate software you can use your SmartCard as an alternative to password protection, but also as a digital signature, for encrypting your e-mails or for home banking.

We recommend that you always use two SmartCards. Always keep one of the SmartCards in a safe place if you are carrying the other SmartCard with you.

In order to be able to take advantage of all the security features of your notebook, you will need a CardOS SmartCard from Fujitsu Technology Solutions.



The SmartCard can only be used with a PIN, offering maximum protection even if you lose the SmartCard. In order to maximise your security, the CardOS SmartCard is disabled if three incorrect attempts are made to enter the PIN.

When you use the CardOS SmartCard for the first time, you will either need to enter the preset PIN "12345678" or the PIN given to you by your systems administrator.

Inserting the SmartCard



Do not use force when inserting and removing the SmartCard.

Make sure that foreign objects do not fall into the SmartCard reader.

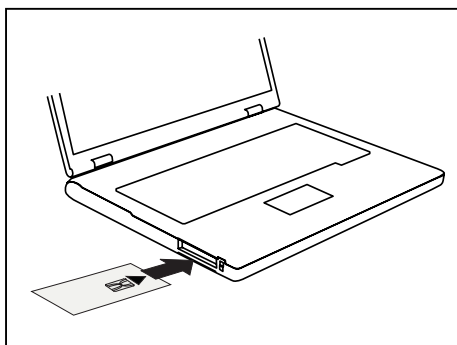

- ▶ Slide the SmartCard into the SmartCard reader with the chip facing upwards (on some variants it faces down) and to the front.

SmartCard as software protection (SmartCase™ Logon+)

Together with a CardOS SmartCard, software like SmartCase™ Logon+ gives you the option of logging on with the SmartCard and entering your PIN. If the PIN is entered correctly, SmartCard is checked and the operating system is booted. The SmartCard must remain in the SmartCard reader during the entire work session.

In addition, the software allows you to block your computer during breaks. This allows you to leave your notebook unattended, without the risk of unauthorised persons being able to access your opened documents and data.



The settings for blocking access to the computer during a session are set up in SmartCase™ Logon+ under *OS Logon (Smarty)*. Among other things, Smarty allows you to specify how users should log on to the operating system, e.g.:

- Fingerprint (without a SmartCard)
- TPM with PIN (without a SmartCard)
- Windows password
- SmartCard with PIN, with fingerprint or with PIN and fingerprint

To install, configure and use SmartCase™ Logon+, please refer to the documentation and online help on the CD with the SmartCase™ Logon+ software.

Proceed as follows to block your computer when you want to take a break:

- ▶ Pull the SmartCard out of the notebook during your work session.
- ↳ A window appears stating that the system is locked.
- ▶ When you want to continue with your work, insert the SmartCard and enter your PIN.
- ↳ You will automatically return to your opened documents.

Trusted Platform Module (TPM) (device-dependent)

To use the TPM, you **must** activate the TPM in the *BIOS Setup* before the software is installed. The condition for this is that you have assigned at least the supervisor password (see "[Setting the supervisor and user password](#)", Page 36).

Options for using the TPM

You can use the TPM in different ways:

SmartCase™ Logon+	<p>SmartCase™ Logon+ offers additional help with managing and using the numerous passwords required to work with the computer.</p> <p>To install, configure and use SmartCase™ Logon+, please refer to the documentation and online help on the CD with the SmartCase™ Logon+ software.</p>
Security API	<p>Smart Security API 4.1 is middleware which supports the entire range of mobile and stationary clients from Fujitsu Technology Solutions. Independent of the TPM hardware, it is needed by everyone who uses a PKI Smart Security environment for identification purposes.</p>
Microsoft® BitLocker	<p>BitLocker Drive Encryption (BDE) is a feature of Microsoft® Vista Enterprise and Ultimate Editions for encryption of the hard disk drive. Here, BitLocker uses the TPM for the storage of the recovery data which are used for decryption of the partition.</p> <p>It is also possible to use BitLocker without TPM and to use just the USB Dongle for the storage of the encryption key. This option is particularly interesting if Vista is installed on a computer on which either an older version of TPM (pre version 1.2) or no TPM is installed.</p> <p>A requirement for BitLocker is that you must have set up at least two partitions on your hard disk. The first partition contains the booting information. The second, larger partition is encrypted and contains the operating system and the user data.</p> <p>Important: The partitions must be set up before Windows Vista is installed.</p>

Enabling TPM

- ▶ Call up the BIOS Setup and select the *Security* menu.
- ▶ Mark the field *TPM Security Chip Setting* (LIFEBOOK) or *TPM Configuration* (ESPRIMO Mobile) and press Enter.
- ▶ Select *Enabled* to activate the TPM.
- ↳ Once you have activated the TPM the *Clear Security Chip* option appears.
Select *Clear Security Chip* to delete the holder in the TPM. By clicking on *Enabled*, all secret keys (e.g. SRK - Storage Root Keys, AIK - Attestation Identity Keys etc.) generated by applications are deleted.
Please note that you will then no longer be able to access the data you have encrypted with the keys based on that holder.
- ▶ Select the *Exit Saving Changes* option in the Exit menu.
- ▶ Press the Enter key and select *Yes*.
- ↳ The notebook will restart, and TPM will be enabled after the reboot.

Disabling TPM

- ▶ Call up the BIOS Setup and select the *Security* menu.
- ▶ Mark the field *TPM Security Chip Setting* (LIFEBOOK) or *TPM Configuration* (ESPRIMO Mobile) and press Enter.
- ▶ Select *Disabled* to deactivate the TPM.
- ▶ From the *Exit* menu, choose the option *Exit Saving Changes*.
- ▶ Press the Enter key and select *Yes*.
- ↳ Your notebook will now restart and TPM will be disabled.

Connecting external devices



Under all circumstances, please observe the safety notes provided in the ["Important notes", Page 3](#) chapter.

Read the documentation on the external device before connecting it.

Do not connect or disconnect cables during a thunderstorm.

Do not pull on the cable when disconnecting a cable. Always take hold of the actual plug.

Follow the steps below in order, when connecting or disconnecting devices to your notebook:

Connecting devices to the notebook

1. Turn off all power and equipment switches.
2. Remove power plugs from the mains outlets for all devices.
3. Connect all the cables to the notebook and the external devices.
4. Plug all data communication cables into the appropriate ports for the data networks.
5. Plug all power cables into the mains outlets.



Please note that connected external devices can discharge the battery of the notebook if no mains adapter is connected to the port replicator.

Disconnecting devices from the notebook

1. Turn off all power and equipment switches.
2. Remove power plugs from the mains outlets for all devices.
3. Unplug all data communication cables from the ports for the data networks.
4. Disconnect all the cables from the notebook and the external devices.



Information about the connections on your notebook can be found in the corresponding EasyGuide.

Connecting an external monitor

You can connect an external monitor to the notebook's VGA or DVI port. Information about the resolutions supported by the graphics card of your notebook can be found in the "Technical Data" chapter in the EasyGuide.

You can use a key combination to switch back and forth between the external monitor and the notebook's LCD screen. More information about the device-specific key combinations can be found in "Key combinations" in the EasyGuide.

Connecting an external monitor to the notebook

- ▶ Switch off the notebook and the external monitor.
- ▶ Connect the data cable of the external monitor directly to the VGA port or the DVI port of the notebook.
- ▶ First switch on the monitor and then the notebook.



When the notebook is connected to a Port Replicator, the operating system creates a hardware profile for the "Docked" mode. In this profile, a setting is saved which indicates the last screen that was used for output. This profile is loaded whenever the notebook is connected to a Port Replicator of the same type.

Setting the refresh rate for your external monitor

The refresh rate must be correctly set so that the image does not flicker.

Windows XP:

- ▶ To do this, select the monitor type in the menu *Start - (Settings) - Control Panel - Appearance and Themes - Display - Settings - Advanced - Display*.
- ▶ Adjust the refresh rate and then click on *Apply*.

Windows Vista:

- ▶ Set the appropriate refresh rate for the connected monitor type.
- ▶ Select *Start - (Settings) - Control Panel - Appearance and personalization - Personalization - Adjust screen resolution*.

or

- ▶ Right-click on the desktop. Click on *Personalize - Display Settings* and select monitor type 1 or 2.
- ▶ Select *Advanced Settings - Monitor*.
- ▶ Select *Screen Refresh Rate* to choose the optimum refresh rate for the connected monitor type.
- ▶ Click *Apply* and *OK*.



If the refresh rate set is too high, the monitor may be damaged. Please see the documentation included with your monitor for the maximum possible refresh rate.

Connecting USB devices (printer, mouse, keyboard, etc.)

On the USB ports you can connect external devices that also have a USB interface (e.g. a printer, a mouse, a keyboard or a scanner).



USB devices are hot-pluggable. This means you can connect and disconnect devices while your operating system is running.

Additional information can be found in the documentation for the USB devices.

- ▶ Connect the data cable to the external device.
- ▶ Connect the data cable to a USB port of the notebook.
- ▶ If necessary, connect the power cable of the USB device to a mains socket.
- ▶ If necessary, connect the USB device.

Device drivers



The devices you connect to the USB ports usually require no driver of their own, as the required software is already included in the operating system. However, if the USB device requires its own software, please install it from the data carrier provided with the USB device.

Connecting external audio devices

High Definition Audio



Depending on your particular model of notebook, it may be equipped with the HDA (High Definition Audio) function. As soon as an audio device is connected to one of the audio sockets, a popup window of the audio driver appears on the screen. In this window you can enter which audio device you have connected (e.g. headphones or loudspeakers on the audio output). This ensures an optimum sound experience.

Microphone port

You can connect an external microphone to your notebook via the microphone port.

Audio output (Line out)/SPDIF (optional)

You can connect either headphones or external loudspeakers to your notebook via the audio output/SPDIF.

Connecting an external device to S-Video Out (device-dependent)

You can connect a TV set or a projector to the notebook.

- ▶ Switch off the notebook and the external device.
- ▶ Connect the external device to the S Video Out socket of your notebook.
- ▶ First switch the external device on and then the notebook.

Activating the external TV / projector

- ▶ To do this, select the monitor type in the menu *Start - (Settings) - Control Panel - Appearance and Themes - Display - Settings - Advanced - Display*.
- ▶ Click on *Apply*.



The specified path relates to the advanced settings view in your Microsoft operating system.

In the menu *Start - Control Panel - Appearance and Themes - Display - Settings - Advanced - "Graphics card folder"* (for Intel: e.g. Intel External Graphics) you can select which key combination is used to switch over the screen output.

Connecting FireWire devices (device-dependent)

External devices such as digital audio/video devices or other high-speed devices can be connected to the FireWire port. The FireWire port operates at a speed of up to 400 Mbit per second.



FireWire devices are hot-pluggable. Therefore, the cables of FireWire devices can be connected and disconnected with the system switched on. Further information may be found in the documentation for the FireWire devices.

- ▶ Connect the data cable of the external devices to the FireWire port of the notebook.
- ▶ Plug the power cable of the external device into the mains socket.

Energy saving functions

The notebook uses less energy when the available energy saving functions are used. You will then be able to work for longer before having to recharge the battery.

Windows XP:

You can set the power-management features for your notebook under *Start - (Settings) - Control Panel - Power Options*.

Windows Vista:

You can set the power-management features for your notebook under *Start - Control Panel - Mobile PC - Power Options*.



Additional information on this service programme is contained in your operating system help files.



When you close the notebook with the On/Off button (press and hold for at least 4 seconds), this can result in loss of data. Always shut the operating system down properly.

When you are finished working with your notebook we advise you to come out of an energy saving mode and then turn off as normal.

If the notebook is in an energy-saving mode:

- Do not connect any external devices.
- Do not disconnect any external devices.
- Do not disconnect the notebook from the Port Replicator.
- Do not attempt to switch the notebook on if the built-in battery is flat.
- Do not add or remove an ExpressCard.
- Do not replace or remove the battery.

Standby mode

- ▶ Press the ON/OFF button to switch the Standby mode on and off.



Windows XP:

You can configure the ON/OFF button under *Start –(Settings) - Control Panel - Performance and Maintenance - Power Options - Advanced*.

Windows Vista:

You can configure the ON/OFF switch under *Start symbol - (Settings) - Control Panel - Mobile PC - Power Options - Advanced*.

In the Standby/Suspend-to-DRAM mode the content of your main memory is saved by continuing to supply the main memory with power, while the processor, monitor, hard disk and other internal components are switched off. This mode is activated whenever you press the ON/OFF button. Saving is also triggered when you do not make an entry on your notebook for a certain time. When you resume work, your notebook returns to the place at which you discontinued working.

Windows XP:

You can set the power-management features for your notebook under *Start – (Settings) - Control Panel - Performance and Maintenance - Power Options*.

Windows Vista:

You can set the power-management features for your notebook under *Start - (Settings) - Control Panel - Mobile PC - Power Options*.



If you are using an integrated LAN/Modem, a PC-LAN card or a PC modem card, please be aware that switching over to Standby mode can lead to an interruption in the network connection.

Your notebook will switch off if you press the ON/OFF button for more than 4 seconds.



Additional information on this service programme is contained in your operating system help files.

Settings in BIOS Setup

In *BIOS Setup* you can set the system functions and the hardware configuration of the notebook. The settings can only be changed via the keyboard.

When it is delivered, the notebook is set to factory default settings. You can change these settings in the menus of the *BIOS Setup*. Any changes you make take effect as soon as you save and quit the *BIOS Setup*.

The *BIOS Setup* contains the following menus:

BIOS Setup starting

- ▶ Restart the notebook (switch OFF and back ON or perform a restart).
- ↳ The following display briefly appears at the bottom edge of the screen during start-up:
<ESC> Diagnostic screen <F12> Boot Menu <F2> BIOS Setup
- ▶ When this message appears, press the function key **[F2]**.



If a password has been assigned:

- ▶ Enter the password and press the Enter key.

If you have forgotten the password, contact your system administrator or our Hotline/Help Desk.

Using the BIOS Setup



Press the **[F1]** key to call up help about using the *BIOS setup*. A description of the individual settings will be displayed in the right-hand window of the *BIOS setup*. You can press the **[F9]** key to load the default settings for the current *BIOS setup* menu.

- ▶ Use the cursor keys **[←]** or **[→]** to select the menu in which you would like to make changes.
- ▶ Press the Enter key.
- ↳ The menu is displayed on the screen.
- ▶ Use the cursor keys **[↑]** or **[↓]** to select the field you wish to change.
- ▶ Press the Enter key to confirm your selection.
- ▶ Press the **[ESC]** key to exit the selected menu.
- ▶ Note the changed entries.

Exiting the BIOS Setup

To exit BIOS Setup, select the *Exit* menu from the menu bar. You can then decide which settings you want to save. To do this, the *Exit* menu offers the following options.

You must mark the required option and activate it with the Enter key.

Exit Saving Changes

Select *Exit Saving Changes* and *Yes* to save the current settings and exit *Bios Setup*. The device is rebooted and the new settings come into effect.

Exit Discarding Changes

To discard the changes, select *Exit Discarding Changes* and *Yes*. The settings which were in force when the *BIOS Setup* was called remain effective. *BIOS Setup* is terminated and the device is rebooted.

Load Setup Default

To revert all menus of the *BIOS Setup* to the default settings, select *Load Setup Default* and *Yes*.

Discard Changes

To load the values for all menus which were active when the *BIOS Setup* was called, select *Discard Changes* and *Yes*. If you want to exit *BIOS Setup* with these settings, select *Exit Saving Changes* and *Yes*.

Save Changes

To save settings without exiting *BIOS Setup*, select *Save Changes* and *Yes*.

Troubleshooting and tips



Refer to the safety information in the "Safety" manual, when connecting or disconnecting cables.

Help if problems occur

Should you ever have a problem with your computer that you cannot solve yourself, in many cases you can solve it quickly using the *SystemDiagnostics* program pre-installed on your computer.

- ▶ To start the *SystemDiagnostics* programme, click on *Startsymbol - Program - Fujitsu Siemens Computers - SystemDiagnostics*

or

- ▶ To start the *SystemDiagnostics* programme, click on *Startsymbol - Program - Fujitsu - SystemDiagnostics*.
- ▶ If a problem is detected during the test run, the *SystemDiagnostics* program outputs a code (e.g. DIFS code YXXX123456789123).
- ▶ Take a note of this DIFS code and the ID number of your device. The ID number can be found on the type rating plate on the back of the casing.
- ▶ For further clarification of the problem, contact the Help Desk for your country (see the Help Desk list or visit the Internet at "<http://ts.fujitsu.com/support>"). For this, please have ready the ID number & serial number of your system and the DIFS code.

Troubleshooting



More information about the device-specific key combinations can be found in "Key combinations" in the EasyGuide.

The notebook's date or time is incorrect

Cause	Troubleshooting
Time and date are incorrect.	<ul style="list-style-type: none"> ▶ Double-click on the clock in the task bar and adjust the time. or ▶ Set the time or date in the <i>Main</i> menu in the <i>BIOS Setup</i>.
The backup battery installed in the notebook is flat.	<p>If the time and date are repeatedly incorrect after switching on the notebook</p> <ul style="list-style-type: none"> ▶ If that problem exists further more please contact our service.

No display appears on the screen, the power-on indicator flashes

Cause	Troubleshooting
The screen power-management feature may be active.	▶ Press any key to activate the display
The notebook is in Standby or Suspend mode.	▶ Press the ON/OFF button to end Standby or Suspend mode.
The display angle or brightness may not be properly adjusted.	▶ Change the angle of the display and adjust the brightness by pressing the corresponding key combination for <i>Increasing the screen brightness</i> or <i>Decreasing the screen brightness</i> as required until the picture is right.
The notebook is set so that the picture only appears on the external screen.	▶ Press the key combination for <i>Switching the screen output</i> to switch over the display to the LCD screen or to specify simultaneous display on the LCD screen and the external screen.

The notebook's LCD screen remains blank

Cause	Troubleshooting
The screen power-management feature may be active	▶ Press any key to activate the display.
The notebook is in Standby or Suspend mode.	▶ Press the ON/OFF button to end Standby or Suspend mode.
The display angle or brightness may not be properly adjusted.	▶ Change the angle of the display and adjust the brightness by pressing the corresponding key combination for <i>Increasing the screen brightness</i> or <i>Decreasing the screen brightness</i> as required until the picture is right.
The notebook is set so that the picture only appears on the external screen.	▶ Press the key combination for <i>Switching the screen output</i> to switch over the display to the LCD screen or to specify simultaneous display on the LCD screen and the external screen.
External monitor or television set is connected.	▶ In <i>BIOS Setup</i> in the <i>Advanced - Video Features</i> menu, set the Display Settings setting to <i>Internal Flat Panel</i> .

The LCD screen is difficult to read

Cause	Troubleshooting
Reflected glare	▶ Turn the notebook or alter the tilt of the LCD screen.
Brightness control is set to dark.	▶ Set the brightness control of the LCD screen to bright.
Incorrect screen resolution set	<p>Windows XP:</p> <p>▶ Set the correct screen resolution: <i>Start - (Settings) - Control Panel - Display - Settings</i>. The correct screen resolution for your notebook can be found under "Technical Data" in the EasyGuide.</p> <p>Windows Vista:</p> <p>▶ Set the correct screen resolution: <i>Start symbol - (Settings) - Control Panel - Appearance and Personalization - Personalization: Adjust screen resolution</i>. The correct screen resolution for your notebook can be found under "Technical Data" in the EasyGuide.</p>

The external monitor remains blank

Cause	Troubleshooting
Monitor is switched off	▶ Switch the external monitor on.
Power saving has been activated (monitor is blank).	▶ Press any key to continue.
Brightness control is set to dark.	▶ Adjust the brightness control.
Screen output is set to the notebook's LCD screen	▶ Press the key combination for <i>Switching the screen output</i> to switch over the display to the external screen or to specify simultaneous display on the LCD screen and the external screen.
The external monitor's power cable or data cable is not connected properly	<p>▶ Switch off the external monitor and the notebook.</p> <p>▶ Check whether the power cable is plugged properly into the external monitor and into the power socket.</p> <p>▶ Check whether the data cable is properly connected to the notebook and the external monitor (if it is plugged in with a connector).</p> <p>▶ Switch on the external monitor and the notebook.</p>

The external monitor is blank or the image is unstable

Cause	Troubleshooting
<p>The wrong external monitor has been selected or the wrong screen resolution has been set for the application programme.</p>	<p>Windows XP:</p> <ul style="list-style-type: none"> ▶ Terminate the application program in Windows by pressing [Alt] + [F4]. ▶ If the fault persists after closing down the program, press the key combination for <i>Switching the screen output</i> to switch to the LCD screen of the notebook and change the following settings: ▶ Select the correct monitor or set the correct screen resolution. <ul style="list-style-type: none"> – Select the monitor: <i>Start - (Settings) - Control Panel - Display - Settings - Advanced - Monitor</i> – Set the screen resolution: <i>Start - (Settings) - Control Panel - Display - Settings , Screen resolution</i> field. <p>Windows Vista:</p> <ul style="list-style-type: none"> ▶ Terminate the application program in Windows by pressing [Alt] + [F4]. ▶ If the fault persists after closing down the program, press the key combination for <i>Switching the screen output</i> to switch to the LCD screen of the notebook and change the following settings: ▶ Set the screen resolution: Select the desired screen resolution under <i>Start – (Settings) – Control Panel – Appearance and Personalization – Personalization: Adjust screen resolution</i> ▶ Select monitor: Right-click on the desktop. From the menu click on <i>Personalize – Display Settings</i> and select monitor 1 or 2 and then select the correct screen under <i>Advanced settings – Monitor</i>.

Battery indicator no longer appears in status indicator panel

Cause	Troubleshooting
No battery installed or no contact between notebook and battery.	<ul style="list-style-type: none"> ▶ Check whether the battery is installed correctly in its compartment. <p>or</p> <ul style="list-style-type: none"> ▶ Charge the battery. ▶ If the operating time of the battery life is extremely short, the battery is probably too old. Replace battery if necessary.

The battery discharges too quickly

Cause	Troubleshooting
The battery is either too hot or too cold. In this case the battery indicator flashes.	<ul style="list-style-type: none"> ▶ Bring the notebook up/down to a normal temperature again. ▶ If the operating time of the battery life is extremely short, the battery is probably too old. Replace battery if necessary.
You may have an application running that consumes a great deal of power due to frequent accessing of the hard disk or optical drive.	<ul style="list-style-type: none"> ▶ Use the mains adapter as frequently as possible.
The maximum brightness may have been set for the screen.	<ul style="list-style-type: none"> ▶ Set the screen slightly darker with the key combination for <i>Decreasing the screen brightness</i> in order to reduce the amount of power being drawn.
The energy-saving functions have been deactivated.	<p>Windows XP:</p> <ul style="list-style-type: none"> ▶ Check the settings in the BIOS Setup (in the <i>Power</i> menu) and under Windows (<i>Start - (Settings) - Control Panel - Power Options</i>) and adjust the parameters. <p>Windows Vista:</p> <ul style="list-style-type: none"> ▶ Check the settings in the BIOS Setup (in the <i>Power</i> menu) and under Windows (<i>Start - (Settings) - Control Panel - Mobile PC - Power Options</i>), and adjust the parameters.

The notebook cannot be started

Cause	Troubleshooting
The battery is not installed correctly.	<ul style="list-style-type: none"> ▶ Switch the notebook off. ▶ Check whether the battery is installed correctly in its compartment. ▶ Switch the notebook on.
The battery is flat.	<ul style="list-style-type: none"> ▶ Charge the battery. <p>or</p> <ul style="list-style-type: none"> ▶ Install a charged battery. <p>or</p> <ul style="list-style-type: none"> ▶ Connect the notebook to a mains outlet using the mains adapter.
The mains adapter is not connected correctly.	<ul style="list-style-type: none"> ▶ Switch the notebook off. ▶ Check whether the mains adapter is connected correctly to the notebook. ▶ Check whether the power cable is plugged properly into the power adapter and into the electrical outlet. ▶ Switch the notebook on.

The notebook does not react

Cause	Troubleshooting
The notebook is in Standby or Suspend mode.	<ul style="list-style-type: none"> ▶ Disable Standby mode (press a key) or Suspend mode (switch notebook on).
The application program has caused the malfunction	<ul style="list-style-type: none"> ▶ Close the application program or restart the notebook (by switching it off and on or by performing a warm boot).
The battery is dead.	<ul style="list-style-type: none"> ▶ Charge the battery. <p>or</p> <ul style="list-style-type: none"> ▶ Install a charged battery. <p>or</p> <ul style="list-style-type: none"> ▶ Connect the notebook to a mains outlet using the mains adapter.

The notebook shuts down suddenly

Cause	Troubleshooting
If you are operating the notebook with a battery, you may have overlooked the reference to the low battery level and the notebook has switched over to Standby mode.	<ul style="list-style-type: none"> ▶ Connect the mains adapter. ▶ Press the ON/OFF button.

The ON/OFF button does not respond properly

Cause	Troubleshooting
The system may be processing.	▶ Wait until the system has completed processing.
You have not pressed the ON/OFF button long enough to switch off the notebook.	▶ Press the ON/OFF button until the notebook switches off.
The Standby function has been deactivated in the BIOS Setup.	<ul style="list-style-type: none"> ▶ While the system is booting, press the function key [F2], to access the BIOS Setup. ▶ Activate the <i>Standby</i> function in the <i>Power</i> menu

The wireless connection to a network does not work



Details are contained in the online help for your wireless LAN software and in the "Wireless LAN" manual. The "Wireless LAN" manual can be found on the "Drivers & Utilities" CD/DVD.

You can find more information on how to use Bluetooth on the CD you received with your Bluetooth software.

Cause	Troubleshooting
The ON/OFF switch for the wireless LAN/Bluetooth module is in the "OFF" position.	▶ Switch your radio component on (refer to the section entitled "Switching the radio components on and off" in the EasyGuide).
The ON/OFF switch for the wireless LAN/Bluetooth module is in the "ON" position. Despite this, the wireless connection to a network cannot be established.	<ul style="list-style-type: none"> ▶ Check whether the radio connection is switched on via the software. ▶ Check if the modules in BIOS are activated.

The mouse does not work

Cause	Troubleshooting
Mouse driver is not loaded	▶ Check whether the correct mouse driver is properly installed and is present before the application programme is started. Detailed information can be found in the User guides for the mouse or application programme.
Mouse is not connected	<ul style="list-style-type: none"> ▶ Switch the notebook off. ▶ Check whether the mouse cable is correctly connected to the notebook. ▶ If you use an adapter or extension lead with the mouse cable, check the connections. ▶ Switch the notebook on.

The printer does not print

Cause	Troubleshooting
Printer not ready-for-use	▶ Make sure that the printer is switched on and is online (see the manuals supplied with the printer).
Data line between notebook and printer interrupted	▶ Check that the cable connecting the notebook and the printer is connected properly.
Wrong printer driver installed	▶ Check that the correct printer driver is installed.
Wrong printer settings	▶ Check the printer settings in Windows.
Wrong port used	▶ Check the entry for the port used in the <i>BIOS Setup</i> in the <i>Advanced - Serial/Parallel Port Configurations</i> menu. The relevant entry in the <i>Serial Port</i> or <i>Parallel Port</i> field must match the setting in the application program under Windows.

No sound or audio signal to the internal or external loudspeakers

Cause	Troubleshooting
Volume set incorrectly	<p>Windows XP:</p> <ul style="list-style-type: none"> ▶ Make sure that the sound driver is correctly installed under <i>Control Panel - System - Hardware - Device Manager</i>. ▶ Press the key combination for <i>Switching the loudspeakers on/off</i> to check whether the loudspeakers are switched off. ▶ Double-click on the volume indicator in the task bar and adjust the volume. or ▶ Press the key combination for <i>Increasing/decreasing the volume</i> to check the volume. <p>Windows Vista:</p> <ul style="list-style-type: none"> ▶ Make sure that the sound driver is correctly installed under <i>Control Panel - System and Maintenance - System - Device Manager</i>. ▶ Press the key combination for <i>Switching the loudspeakers on/off</i> to check whether the loudspeakers are switched off. ▶ Double-click on the volume indicator in the task bar and adjust the volume. or ▶ Press the key combination for <i>Increasing/decreasing the volume</i> to check the volume.
Incorrect audio settings	<p>Windows XP only:</p> <ul style="list-style-type: none"> ▶ Check the audio settings of the sound card or the audio driver. ▶ If necessary, activate the setting <i>Output digital and analog</i> in the field <i>SPDIF</i>.

The CD/DVD does not work – no sound during CD/DVD playback

Cause	Troubleshooting
CD inserted incorrectly	<ul style="list-style-type: none"> ▶ Check whether the CD/DVD has been properly inserted into the drive.
CD faulty or not standard	<ul style="list-style-type: none"> ▶ Check whether the CD/DVD is scratched, warped, dirty or damp. ▶ Make sure that you use a CD/DVD that complies with the standards.
Loudspeaker	<ul style="list-style-type: none"> ▶ Press the key combination for Switching the loudspeakers on/off to check whether the loudspeakers are switched off. ▶ Press the key combination for <i>Increasing/decreasing the volume</i> to check the volume.

User and/or supervisor password forgotten

Cause	Troubleshooting
Forgotten password	<ul style="list-style-type: none"> ▶ If you have forgotten your user password, enter the supervisor password or contact your system administrator. ▶ If the supervisor password is also no longer available, please contact our Hotline/Help Desk. You must provide proof of ownership for the notebook. The helpdesk will then refer you to our service partner, who will unlock your notebook (for a charge).

Acoustic warnings

Cause	Troubleshooting
A beep sounds every few seconds The battery is almost flat.	<ul style="list-style-type: none"> ▶ Charge the battery.

Error messages on the screen

This section describes the error messages generated by the BIOS Setup. Error messages displayed by the operating system or programmes are described in the relevant documentation.



If the error message appears repeatedly, despite troubleshooting measures, please contact the place of purchase or our customer service centre.

Error message/cause	Troubleshooting
<p><i>CMOS Battery Bad</i></p> <p>If the error message occurs repeatedly, the buffer battery in the notebook is flat.</p>	<ul style="list-style-type: none"> ▶ Please contact your sales outlet or our customer service centre.
<p><i>System CMOS checksum bad - Default configuration used</i></p> <p>The system configuration information is incorrect.</p>	<ul style="list-style-type: none"> ▶ Switch the notebook off. ▶ Switch the notebook on. ▶ Press the function key [F2] to access the <i>BIOS Setup</i>. ▶ In the <i>BIO Setup</i>, select the <i>Exit</i> menu. ▶ Select the entry <i>Load Setup Defaults</i>. ▶ Select <i>OK</i> and press the Enter key.
<p><i>Extended memory failed at offset: xxxx Failing Bits: zzzz zzzz</i></p> <p>When testing the extended memory an error has resulted at the address xxxx.</p>	<ul style="list-style-type: none"> ▶ Check whether the additional memory module has been inserted correctly.
<p><i>Failure Fixed Disk n</i></p> <p>The settings of the hard disk drive are incorrect.</p>	<ul style="list-style-type: none"> ▶ Start the <i>BIOS Setup (Primary Master submenu)</i> and select the correct settings.
<p><i>Keyboard controller error</i></p>	<ul style="list-style-type: none"> ▶ Switch the notebook off using the ON/OFF button. ▶ Wait 3 - 5 seconds and switch on the notebook again.
<p><i>Keyboard error</i></p>	<ul style="list-style-type: none"> ▶ If you use an external keyboard: ▶ Check the connection and reboot the notebook.
<p><i>nn Stuck key</i></p>	<ul style="list-style-type: none"> ▶ Make sure that no key is pressed.
<p><i>Operating system not found</i></p>	<ul style="list-style-type: none"> ▶ Check in the <i>BIOS Setup</i> whether your hard disk has been set correctly. ▶ Make sure that the operating system is installed on the corresponding drive.
<p><i>Press <F1> to resume, <F2> to SETUP</i></p> <p>This error message appears if an error occurs during the self-test before starting the operating system.</p>	<ul style="list-style-type: none"> ▶ Press the [F1] function key to start the operating system. ▶ Press the function key [F2] to access the <i>BIOS Setup</i>.

<i>Previous boot incomplete - Default configuration used</i> Due to an error during the previous system boot, default values were used for certain settings. Check the settings in the BIOS Setup.	▶ Press the <input type="text" value="F1"/> function key when prompted to do so.
<i>Real Time clock error</i>	▶ Please contact your sales outlet or our customer service centre.
<i>nnnnK Shadow RAM failed at offset: xxxx Failing Bits: zzzz</i>	▶ Please contact your sales outlet or our customer service centre.
<i>System battery is dead - Replace and run SETUP</i>	▶ Please contact your sales outlet or our customer service centre.
<i>System cache error - Cache disabled</i>	▶ Please contact your sales outlet or our customer service centre.
<i>System timer error</i>	▶ Please contact your sales outlet or our customer service centre.

Restoring the hard disk contents under Windows

You can reinstall the operating system with the "Windows Recovery CD" and the "Drivers & Utilities" CD/DVD.

The instructions are provided on the case of the Recovery CD.



During the reinstall process your personal files and any installed programs will be deleted. We advise you to backup your files to an external hard drive, or CD / DVD disk before you start.

- ▶ Switch the notebook on.
 - ↳ The following display briefly appears on the screen during start-up:
<ESC>Diagnostic screen <F12>Boot Menu <F2>BIOS Setup
 - ▶ When this message appears, press the function key .
 - ▶ Insert the "Windows Recovery CD" into the optical drive.
 - ▶ Select *CD-ROM* and press the Enter key.
 - ▶ Follow the instructions on the screen.
- After the installation you must install all the drivers again. Some installed hardware components will not be correctly supported until this has been done.
- ▶ Insert the "Drivers & Utilities" CD/DVD into the optical drive. The CD starts automatically.
 - ▶ Click on the *Desk Update* button.
 - ▶ Select *Automatic driver installation (Express)* and click on *Start installation*.
 - ▶ Follow the instructions on the screen.
 - ▶ Restart your notebook when the driver installation is completed.

Manufacturer's notes

Disposal and recycling

Information about this subject can be found on your notebook or on our Internet pages.

Copyright-protected technology

This product incorporates copyright protection technology that is protected by method claims of certain U. S. patents and other intellectual property rights owned by Macrovision Corporation and other rights owners. Use of this copyright protection technology must be authorised by Macrovision Corporation, and is intended for home and other limited viewing uses only unless otherwise authorised by Macrovision Corporation. Reverse engineering or disassembly is prohibited.

CE marking



The shipped version of this device complies with the requirements of EEC directives 2004/108/EC "Electromagnetic compatibility" and 2006/95/EC "Low voltage directive".



CE marking for devices with radio component

This equipment complies with the requirements of Directive 1999/5/EC of the European Parliament and Commission from 9 March, 1999 governing Radio and Telecommunications Equipment and mutual recognition of conformity.

This equipment can be used in the following countries:

Belgium	Bulgaria	Denmark	Germany
Estonia	Finland	France	Greece
UK	Ireland	Iceland	Italy
Latvia	Liechtenstein	Lithuania	Luxemburg
Malta	Netherlands	Norway	Austria
Poland	Portugal	Rumania	Sweden
Switzerland	Slovakia	Slovenia	Spain
Czech Republic	Hungary	Cyprus	

Contact the corresponding government office in the respective country for current information on possible operating restrictions. If your country is not included in the list, then please contact the corresponding supervisory authority as to whether the use of this product is permitted in your country.

Regulatory notices



If there is no FCC logo and also no FCC ID on the device then this device is not approved by the Federal Communications Commission (FCC) of the USA. Although it is not explicitly forbidden to travel the US trading area carrying this device, but to avoid trouble at customs clearance Fujitsu Technology Solutions GmbH recommends not to bring this device into the US trading area.

Regulatory information for notebooks without radio device

NOTICE:

Changes or modifications not expressly approved by Fujitsu Technology Solutions could void this user's authority to operate the equipment.

Notice to Users of Radios and Television

These limits are designed to provide reasonable protection against harmful interference in a residential installation. This equipment generates, uses, and can radiate radio frequency energy and, if not installed and used in accordance with the instructions, may cause harmful interference to radio communications. However, there is no guarantee that interference will not occur in a particular installation. If this equipment does cause harmful interference to radio or television reception, which can be determined by turning the equipment off and on, the user is encouraged to try to correct the interference by one or more of the following measures:

- Reorient or relocate the receiving antenna.
- Increase the separation between the equipment and receiver.
- Connect the equipment into an outlet that is on a different circuit than the receiver.
- Consult the dealer or an experienced radio/TV technician for help.

Notice to Users of the US Telephone Network

Your notebook may be supplied with an internal modem which complies with Part 68 of the FCC rules. On this notebook is a label that contains the FCC Registration Number and the Ringer Equivalence Number (REN) for this equipment among other information. If requested, the user must provide their telephone company with the following information:

1. The telephone number to which the notebook is connected.
2. The Ringer Equivalence Number (REN) for this equipment.
3. The equipment requires a standard modular jack type USOC RJ-11C which is FCC Part 68 compliant.
4. The FCC Registration Number.

This equipment is designed to be connected to the telephone network or premises wiring using a standard modular jack type USOC RJ-11C which is FCC Part 68 compliant and a line cord between the modem and the telephone network with a minimum of 26AWG.

The REN is used to determine the number of devices that you may connect to your telephone line and still have all of those devices ring when your number is called. Too many devices on one line may result in failure to ring in response to an incoming call. In most, but not all, areas the sum of the RENs of all of the devices should not exceed five (5). To be certain of the number of devices you may connect to your line, as determined by the RENs, contact your local telephone company. If this equipment causes harm to the telephone network, your telephone company may discontinue your service temporarily. If possible, they will notify you in advance. If advance notice is not practical they will notify you as soon as possible. You will also be advised of your right to file a complaint with the FCC.

This fax modem also complies with fax branding requirements per FCC Part 68.

Your telephone company will probably ask you to disconnect this equipment from the telephone network until the problem is corrected and you are sure that the equipment is not malfunctioning. This equipment may not be used on coin-operated telephones provided by your telephone company. Connection to party lines is subject to state tariffs. Contact your state's public utility commission, public service commission or corporation commission for more information.

This equipment includes automatic dialing capability. When programming and/or making test calls to emergency numbers:

- Remain on the line and briefly explain to the dispatcher the reason for the call.
- Perform such activities in off-peak hours, such as early morning or late evening.

FCC rules prohibit the use of non-hearing aid compatible telephones in the following locations or applications:

- All public or semi-public coin-operated or credit card telephones.
- Elevators, highways, tunnels (automobile, subway, railroad or pedestrian) where a person with impaired hearing might be isolated in an emergency.
- Places where telephones are specifically installed to alert emergency authorities such as fire, police or medical assistance personnel.
- Hospital rooms, residential health care facilities, convalescent homes and prisons.
- Hotel, motel or apartment lobbies.
- Stores where telephones are used by patrons to order merchandise.
- Public transportation terminals where telephones are used to call taxis or to reserve lodging or rental cars.
- In hotel and motel rooms as at least ten percent of the rooms must contain hearing aid-compatible telephones or jacks for plug-in hearing aid compatible telephones which will be provided to hearing impaired customers on request.

DOC (Industry CANADA) notices

Notice to Users of Radios and Television

This Class B digital apparatus meets all requirements of Canadian Interference-Causing Equipment Regulations.

CET appareil numérique de la class B respecte toutes les exigence du Règlement sur le matériel brouilleur du Canada.

Notice to Users of the Canadian Telephone Network

NOTICE:

This equipment meets the applicable Industry Canada Terminal Equipment Technical Specifications. This is confirmed by the registration number. The abbreviation, IC, before the registration number signifies that registration was performed based on a Declaration of Conformity indicating that Industry Canada technical specifications were met. It does not imply that Industry Canada approved the equipment. Before connecting this equipment to a telephone line the user should ensure that it is permissible to connect this equipment to the local telecommunication facilities. The user should be aware that compliance with the certification standards does not prevent service degradation in some situations.

Repairs to telecommunication equipment should be made by a Canadian authorized maintenance facility. Any repairs or alterations not expressly approved by Fujitsu or

any equipment failures may give the telecommunication company cause to request the user to disconnect the equipment from the telephone line.

NOTICE:

The Ringer Equivalence Number (REN) for this terminal equipment is 0.0. The REN assigned to each terminal equipment provides an indication of the maximum number of terminals allowed to be connected to a telephone interface. The termination on an interface may consist of any combination of devices subject only to the requirement that the sum of the Ringer Equivalence Numbers of all the devices does not exceed five.



CAUTION:

For safety, users should ensure that the electrical ground of the power utility, the telephone lines and the metallic water pipes are connected together. Users should NOT attempt to make such connections themselves but should contact the appropriate electric inspection authority or electrician. This may be particularly important in rural areas.

Avis Aux Utilisateurs Du Réseau Téléphonique Canadien

AVIS : Le présent matériel est conforme aux spécifications techniques d'Industrie Canada applicables au matériel terminal. Cette conformité est confirmée par le numéro d'enregistrement. Le sigle IC, placé devant le numéro d'enregistrement, signifie que l'enregistrement s'est effectué conformément à une déclaration de conformité et indique que les spécifications techniques d'Industrie Canada ont été respectées. Il n'implique pas qu'Industrie Canada a approuvé le matériel.

Avant de connecter cet équipement à une ligne téléphonique, l'utilisateur doit vérifier s'il est permis de connecter cet équipement aux installations de télécommunications locales. L'utilisateur est averti que même la conformité aux normes de certification ne peut dans certains cas empêcher la dégradation du service.

Les réparations de l'équipement de télécommunications doivent être effectuées par un service de maintenance agréé au Canada. Toute réparation ou modification, qui n'est pas expressément approuvée par Fujitsu, ou toute défaillance de l'équipement peut entraîner la compagnie de télécommunications à exiger que l'utilisateur déconnecte l'équipement de la ligne téléphonique.

AVIS : L'indice d'équivalence de la sonnerie (IES) du présent matériel est de 0.0. L'IES assigné à chaque dispositif terminal indique le nombre maximal de terminaux qui peuvent être raccordés à une interface téléphonique. La terminaison d'une interface peut consister en une combinaison quelconque de dispositifs, à la seule condition que la somme d'indices d'équivalence de la sonnerie de tous les dispositifs n'exécède pas 5.



AVERTISSEMENT:

Pour assurer la sécurité, les utilisateurs doivent vérifier que la prise de terre du service d'électricité, les lignes téléphoniques et les conduites d'eau métalliques sont connectées ensemble. Les utilisateurs NE doivent PAS tenter d'établir ces connexions eux-mêmes, mais doivent contacter les services d'inspection d'installations électriques appropriés ou un électricien. Ceci peut être particulièrement important en régions rurales.

UL Notice

This unit requires an AC adapter to operate. Only use a UL Listed Class 2 adapter. The correct output rating is indicated on the AC adapter label. Refer to the illustration below for the correct AC Adapter output polarity:



CAUTION:

To reduce the risk of fire, use only 26AWG or larger telecommunications line cord.

For Authorized Repair Technicians Only



CAUTION:

For continued protection against risk of fire, replace only with the same type and rating fuse.



WARNING:

Danger of explosion if Lithium (CMOS) battery is incorrectly replaced. Replace only with the same or equivalent type recommended by the manufacturer.

Dispose of used batteries according to the manufacturer's instructions.

FCC Regulatory information for notebooks with radio device

Federal Communications Commission statement

This device complies with Part 15 of FCC Rules. Operation is subject to the following two conditions: (1) this device may not cause interference, and

(2) this device must accept any interference, including interference that may cause undesired operation of this device.

FCC Interference Statement

This equipment has been tested and found to comply with the limits for a Class B digital device, pursuant to Part 15 of the FCC Rules. These limits are designed to provide reasonable protection against harmful interference in a residential installation. This equipment generates, uses, and can radiate radio frequency energy. If not installed and used in accordance with the instructions, it may cause harmful interference to radio communications.

However, there is no guarantee that interference will not occur in a particular installation.

If this equipment does cause harmful interference to radio or television reception, which can be determined by turning the equipment off and on, the user is encouraged to try to correct the interference by one or more of the following measures:

1. Reorient or relocate the receiving antenna.
2. Increase the distance between the equipment and the receiver.
3. Connect the equipment to an outlet on a circuit different from the one the receiver is connected to.
4. Consult the dealer or an experienced radio/TV technician for help.

Please note the following regulatory information related to the optional radio device.

FCC Radio Frequency Exposure statement

This radio device has been evaluated under FCC Bulletin OET 65C and found compliant with the requirements as set forth in CFR 47 Sections 2.1091, 2.1093, and 15.247 (b) (4) addressing RF

Exposure from radio frequency devices. The radiated output power of this radio device is far below the FCC radio frequency exposure limits. Nevertheless, this device shall be used in such a manner that the potential for human contact during normal operation is minimized. When using this device, a certain separation distance between antenna and nearby persons must be maintained to ensure RF exposure compliance. In order to comply with RF exposure limits established in the ANSI C95.1 standards, the distance between the antennas and the user should not be less than 20 cm (8 inches).

Regulatory Notes and Statements

Radio device, health and authorisation for use

Radio-frequency electromagnetic energy is emitted from the wireless devices. The energy levels of these emissions, however, are far much less than the electromagnetic energy emissions from wireless devices such as mobile phones. Radio devices are safe for use by consumers because they operate within the guidelines found in radio frequency safety standards and recommendations.

The use of the radio devices may be restricted in some situations or environments, such as:

- on board an airplane, or
- in an explosive environment, or
- in situations where the interference risk to other devices or services is perceived or identified as harmful.

In cases in which the policy regarding use of radio devices in specific environments is not clear (e.g., airports, hospitals, chemical/oil/gas industrial plants, private buildings), obtain authorization to use these devices prior to operating the equipment.

Regulatory Information/Disclaimers

Installation and use of this radio device must be in strict accordance with the instructions included in the user documentation provided with the product. Any changes or modifications made to this device that are not expressly approved by the manufacturer may void the user's authority to operate the equipment. The manufacturer is not responsible for any radio or television interference caused by unauthorized modification of this device, or the substitution or attachment of connecting cables and equipment other than those specified by the manufacturer. It is the responsibility of the user to correct any interference caused by such unauthorized modification, substitution or attachment. The manufacturer and its authorized resellers or distributors will assume no liability for any damage or violation of government regulations arising from failure to comply with these guidelines.

Export restrictions

This product or software contains encryption code which may not be exported or transferred from the US or Canada without an approved US Department of Commerce export license. This device complies with Part 15 of FCC Rules, as well as ICES 003 B / NMB 003 B. Operation is subject to the following two conditions:

- (1) this device may not cause harmful interference, and
- (2) this device must accept any interference received, including interference that may cause undesirable operation.

Modifications not expressly authorized by Fujitsu Technology Solutions may invalidate the user's right to operate this equipment.

Index

56k modem 30

A

Acoustic warnings 63
Adjusting the font size 15–16
Adjusting the resolution 15
Alt Gr key 10
Anti-theft protection 34
Audio ports 48

B

Backspace 10
Battery see also rechargeable battery 17
Battery status meter 18
Battery:
 care and maintenance 17
 charging 17
 discharges too quickly 58
 life 17
 monitoring the charge level 18
 no battery indicator 58
 self-discharge 17–18
 storing 17–18
BIOS setup
 using 52
BIOS Setup:
 exiting 52
 password protection 35
 protect with password 35
 settings 52
 starting 52
Bluetooth, safety notes 3
Brief overview of security functions 33
Buttons:
 touchpad 12
 TouchStick 12

C

Caps Lock 10
CardBus, see PC card 25
CD/DVD indicator 22
CD/DVD:
 does not work 63
 handling 22
 inserting 23
 manual emergency removal 23
 removing 23
CD-ROM drive 19

CE marking 66
Charging capacity, battery 17–18
Cleaning 5
Configuration
 BIOS setup 52
Connecting audio devices 48–49
Connecting headphones 48
Contents of delivery 6
Copyright-protected technology 66
Cursor control keys 10
Cursor keys 10

D

Damage during transport 6
Date:
 wrongly set 54
Delivery note 6
Devices:
 connecting 46
 disconnecting 46
Display
 difficult to read 56
Display, difficult to read 56
DOC (INDUSTRY CANADA) NOTICES 68
Drive
 Removing 21
Drive:
 removing 20
DVD+/-R/RW drive 19
DVD-ROM drive 19

E

Emergency removal, CD/DVD 23
Energy saving functions:
 notebook 50
Enter key 10
Error message:
 acoustic messages 63
 on the screen 64
Error messages on the screen 64
Error:
 correction 54
ExpressCard 25
 inserting 26
 removing 28
ExpressCard:
 lowering eject button 25
External devices, connecting 46

- External monitor:
 - connecting to the notebook 47
 - no screen display 57
 - screen display drifts 57
 - stays blank 56
- External screen:
 - selecting the display 16
 - synchronizing the display 16
- F**
- Faults, rectifying 54
- Fingerprint sensor 34
- Fingerprint sensor:
 - configuring 34
- FireWire
 - connecting devices 49
- FireWire:
 - port 49
- Fn key 10
- G**
- Getting started 6
- H**
- Hard disk:
 - restoring the contents 65
- Hardware configuration 52
- HDA, High Definition Audio 48
- High Definition Audio 48
- I**
- Important notes 3
- Indicator: Num Lock 11
- K**
- Kensington Lock
 - using 34
- Kensington Lock:
 - anti-theft protection 34
- Keyboard 9
- Keyboard:
 - cleaning 5
- L**
- LAN 31
- LAN:
 - connecting 31
- LCD screen
 - difficult to read 56
 - remains blank 55
 - settings 15
 - LCD screen is too dark 55–56
- LCD screen:
 - adjusting the resolution 15
 - cleaning 5
 - decreasing brightness 16
 - font size 15–16
 - increasing brightness 16
 - notes 14
 - selecting the display 16
 - synchronizing the display 16
- LCD screen, too bright 56
- Lifetime
 - battery 17
- Loudspeaker:
 - connecting 48
 - no sound 62
- M**
- Mains adapter:
 - connecting 7
 - setting up 6
- Manual removal, CD/DVD 23
- Manufacturer, notes 66
- Memory card:
 - handling 24
 - inserting 24
 - removing 24
 - Secure Digital 24
- Menu key 11
- Microphone:
 - connecting 48
- Mobile operation 4
- Modem 30
- Modem:
 - connecting 30
- Module
 - Removing 21
- Module bay 19
- Module:
 - removing 20
- Modules 19
- Monitor:
 - no display 55
- Mouse does not work 60
- Mouse: no mouse pointer 60
- N**
- Network, no radio connection 60
- Notebook
 - shuts down suddenly 59

- Notebook:
 - not reacting 59
 - not starting 59
 - setting up 6
 - switching on for the first time 8
- Notes
 - disposal / recycling 66
- Notes:
 - important 3
 - LCD screen 14
- Numerical keypad, see virtual number pad 11

- O**
- ON/OFF button 51
- ON/OFF button:
 - not responding 60
- Operating system, restoring 65
- Operation, notebook 9
- Optical drive 22

- P**
- Packaging 6
- Password protection:
 - BIOS Setup 35
 - hard disk 38
 - operating system 37
- Pause key 10
- PC card 25
 - inserting 26
 - removing 28
- PC card:
 - lowering eject button 25
- PC-card, see PC card 25
- PCMCIA, see PC card 25
- Peripherals, see Devices 46
- Pointer, changing the speed 16
- Power-on indicator:
 - flashes 55
- Preparing for operation 7
- Printer:
 - does not print 61
- Projector:
 - activating 49
 - connecting 49

- R**
- Radio component:
 - safety notes 3
- Radio connection does not work 60
- Regulatory information
 - notebooks with radio device 70
 - Notebooks without radio device 67

- Return 10

- S**
- safety information 3
- Screen brightness:
 - decreasing 16
 - increasing 16
- Screen settings 15
- Scroll key 12
- Second battery 19
 - Removing 21
- Second battery:
 - removing 20
- Second hard disk 19
- Secure Digital 24
- Security functions 32
 - Brief overview 33
 - SystemLock 42
- Security functions,
 - SmartCard 42
- Selecting the location 6
- Selecting the monitor 16
- Self-discharge, battery 17–18
- Settings
 - BIOS setup 52
- Setup, see BIOS setup 52
- Shift 10
- Shift key 10
- Slot:
 - memory card 24
- Standby mode 51
- Start key 10–11
- Super-Multi-Format DVD drive 19
- Supervisor password:
 - forgotten 63
- Switching on for the first time 8
- System configuration 52
- System settings
 - BIOS setup 52

- T**
- Tab key 10
- Television set:
 - activating 49
 - connecting 49
- Time:
 - wrongly set 54
- Tips 54
- Touchpad 12
 - executing commands 13
- Touchpad buttons 12

- Touchpad:
 - cleaning 5
 - does not work 60
 - dragging the item 13
 - moving the pointer 13
 - scrolling down 13
 - scrolling up 13
 - selecting an item 13
- TouchStick 12
- TouchStick buttons 12
- TouchStick:
 - dragging the item 13
 - executing the command 13
 - moving the pointer 13
 - scrolling down 13
 - scrolling up 13
 - selecting an item 13
- TPM 44
- Transportation 4
- Travel preparations 4
- Troubleshooting 54
- Trusted Platform Module 44

U

- USB devices:
 - connecting 48
 - software 48
- USB port 48
- User password:
 - forgotten 63

V

- Video devices, connecting 49
- Virtual numeric keypad 11

W

- Weight Saver 19
 - Removing 21
- Weight saver:
 - removing 20
- Weight Saver, see weight saver 19
- Wireless LAN:
 - safety notes 3